



ICE BATH CHILLER

Installation & Instruction Manual



IMPORTANT NOTE:

Thank you very much for purchasing our product. Before using your unit, please read this manual carefully and keep it for future reference.

CONTENT

1. FOREWORD	1
1.1. Read the Manual Before Operation	1
1.2. The Symbol Description of the Device	6
1.3. Statement	6
1.4. Safety Factors	6
2. OVER VIEW OF THE UNIT	9
2.1. Accessories Supplied With the Unit	9
2.2. Dimensions of the Unit	10
2.3. Main Parts of the Unit	11
2.4. Parameter of the Unit	12
3. INSTALLATION AND CONNECTION	14
3.1. Transportation	14
3.2. Installation Instruction	15
3.2.1 Pre-requirements	15
3.2.2 Location and Space	15
3.2.3 Installation Layout	16
3.2.4 Electrical Installation	17
3.2.5 Electrical Connection	18
3.3. Trial After Installation	19
3.3.1 Inspection Before Trial Running	19
3.3.2 Trial Running	19
4. REMOTE CONTROLLER OPERATION GUIDANCE	20
4.1. Key Operating Instruction	21
4.2. Parameter List	24
4.3. Error Code	26
4.4. Trouble Shooting	27
4.5. Other Malfunctions and Solutions(No display on wire controller)	29
4.6. Wi-Fi Settings	30

4.6.1 Software Installation	30
4.6.2 Software Startup	30
4.6.3 Software Registration and Configuration	31
4.6.4 Software Function Operation	38
4.3.5 Device Removal	44
5. MAINTENANCE AND WINTERZING	45
5.1 Maintenance	45
5.2 Disassembly Guidelines	45
5.3 Filter Replacement	47
5.4 UV Lamp Replacement	48
5.5 Winterizing	48

1. FOREWORD

1.1. *Read the Manual Before Operation*

WARNING

Do not use means to accelerate the defrosting process or to clean, other than those recommended by the manufacturer. The appliance shall be stored in a room without continuously operating ignition sources (for example: open flames, an operating gas appliance or an operating electric heater).

Do not pierce or burn.

Be aware that refrigerants may not contain an odour.

Initial safety checks shall include:

- ① That capacitors are discharged: this shall be done in a safe manner to avoid possibility of sparking;
- ② That no live electrical components and wiring are exposed while charging, recovering or purging the system;
- ③ That there is continuity of earth bonding.

Checks to the area

Prior to beginning work on systems containing flammable refrigerants, safety checks are necessary to ensure that the risk of ignition is minimized. For repair to the refrigerating system, the following precautions shall be completed prior to conducting work on the system.

Work procedure

Work shall be undertaken under a controlled procedure so as to minimize the risk of a flammable gas or vapour being present while the work is being performed.

General work area

All maintenance staff and others working in the local area shall be instructed on the nature of work being carried out. Work in confined spaces shall be avoided.

Checking for presence of refrigerant

The area shall be checked with an appropriate refrigerant detector prior to and during work, to ensure the technician is aware of potentially flammable atmospheres. Ensure that the leak detection equipment being used is suitable for use with flammable refrigerants, i.e. non-sparking, adequately sealed or intrinsically safe.

Presence of fire extinguisher

If any hot work is to be conducted on the refrigerating equipment or any associated parts, appropriate fire extinguishing equipment shall be available to hand. Have a dry powder or CO₂ fire extinguisher adjacent to the charging area.

No ignition sources

No person carrying out work in relation to a refrigeration system which involves exposing any pipe work that contains or has contained flammable refrigerant shall use any sources of ignition in such a manner that it may lead to the risk of fire or explosion. All possible ignition sources, including cigarette smoking, should be kept sufficiently far away from the site of installation, repairing, removing and disposal, during which flammable refrigerant can possibly be released to the surrounding space. Prior to work taking place, the area around the equipment is to be surveyed to make sure that there are no flammable hazards or ignition risks. "No Smoking" signs shall be displayed.

Ventilated area

Ensure that the area is in the open or that it is adequately ventilated before breaking into the system or conducting any hot work. A degree of ventilation shall continue during the period that the work is carried out. The ventilation should safely disperse any released refrigerant and preferably expel it externally into the atmosphere.

Checks to the refrigeration equipment

Where electrical components are being changed, they shall be fit for the purpose and to the correct specification. At all times the manufacturer's maintenance and service guidelines shall be followed. If in doubt consult the manufacturer's technical department for assistance.

The following checks shall be applied to installations using flammable refrigerants:

- ① The charge size is in accordance with the room size within which the refrigerant containing parts are installed;
- ② The ventilation machinery and outlets are operating adequately and are not obstructed;
- ③ If an indirect refrigerating circuit is being used, the secondary circuit shall be checked for the presence of refrigerant;
- ④ Marking to the equipment continues to be visible and legible. Markings and signs that are illegible shall be corrected;
- ⑤ Refrigeration pipe or components are installed in a position where they are unlikely to be exposed to any substance which may corrode refrigerant containing components, unless the components are constructed of materials which are inherently resistant to being corroded or are suitably protected against being so corroded.

Repairs to sealed components

DD.5.1 During repairs to sealed components, all electrical supplies shall be disconnected from the equipment being worked upon prior to any removal of sealed covers, etc. If it is absolutely necessary to have an electrical supply to equipment during servicing, then a permanently operating form of leak detection shall be located at the most critical point to warn of a potentially hazardous situation.

DD.5.2 Particular attention shall be paid to the following to ensure that by working on electrical components, the casing is not altered in such a way that the level of protection is affected. This shall include damage to cables, excessive number of connections, terminals not made to original specification, damage to seals, incorrect fitting of glands, etc.

Ensure that the apparatus is mounted securely.

Ensure that seals or sealing materials have not degraded to the point that they no longer serve the purpose of preventing the ingress of flammable atmospheres. Replacement parts shall be in accordance with the manufacturer's specifications.

Repair to intrinsically safe components

Do not apply any permanent inductive or capacitance loads to the circuit without ensuring that this will not exceed the permissible voltage and current permitted for the equipment in use. Intrinsically safe components are the only types that can be worked on while live in the presence of a flammable atmosphere. The test apparatus shall be at the correct rating.

Replace components only with parts specified by the manufacturer. Other parts may result in the ignition of refrigerant in the atmosphere from a leak.

NOTE: The use of silicon sealant can inhibit the effectiveness of some types of leak detection equipment.

Intrinsically safe components do not have to be isolated prior to working on them.

Cabling

Check that cabling will not be subject to wear, corrosion, excessive pressure, vibration, sharp edges or any other adverse environmental effects. The check shall also take into account the effects of aging or continual vibration from sources such as compressors or fans.

Detection of flammable refrigerants

Under no circumstances shall potential sources of ignition be used in the searching for or detection of refrigerant leaks. A halide torch (or any other detector using a naked flame) shall not be used.

Leak detection methods

The following leak detection methods are deemed acceptable for systems containing flammable refrigerants.

Electronic leak detectors shall be used to detect flammable refrigerants, but the sensitivity may not be adequate, or may need re-calibration. (Detection equipment shall be calibrated in a refrigerant-free area.) Ensure that the detector is not a potential source of ignition and is suitable for the refrigerant used. Leak detection equipment shall be set at a percentage of the LFL of the refrigerant and shall be calibrated to the refrigerant employed and the appropriate percentage of gas (25 % maximum) is confirmed.

Leak detection fluids are suitable for use with most refrigerants but the use of detergents containing chlorine shall be avoided as the chlorine may react with the refrigerant and corrode the copper pipe-work.

If a leak is suspected, all naked flames shall be removed/extinguished.

If a leakage of refrigerant is found which requires brazing, all of the refrigerant shall be recovered from the system, or isolated (by means of shut off valves) in a part of the system remote from the leak. Oxygen free nitrogen (OFN) shall then be purged through the system both before and during the brazing process.

Removal and evacuation

When breaking into the refrigerant circuit to make repairs – or for any other purpose – conventional procedures shall be used. However, it is important that best practice is followed since flammability is a consideration. The following procedure shall be adhered to:

- ① Remove refrigerant;
- ② Purge the circuit with inert gas;
- ③ Evacuate;
- ④ Purge again with inert gas;
- ⑤ Open the circuit by cutting or brazing.

The refrigerant charge shall be recovered into the correct recovery cylinders. The system shall be "flushed" with OFN to render the unit safe. This process may need to be repeated several times. Compressed air or oxygen shall not be used for this task.

Flushing shall be achieved by breaking the vacuum in the system with OFN and continuing to fill until the working pressure is achieved, then venting to atmosphere, and finally pulling down to a vacuum. This process shall be repeated until no refrigerant is within the system. When the final OFN charge is used, the system shall be vented down to atmospheric pressure to enable work to take place. This operation is absolutely vital if brazing operations on the pipework are to take place.

Ensure that the outlet for the vacuum pump is not close to any ignition sources and there is ventilation available.

Charging procedures

In addition to conventional charging procedures, the following requirements shall be followed:

- ① Ensure that contamination of different refrigerants does not occur when using charging equipment. Hoses or lines shall be as short as possible to minimize the amount of refrigerant contained in them. Cylinders shall be kept upright.
- ② Ensure that the refrigeration system is earthed prior to charging the system with refrigerant.
- ③ Label the system when charging is complete (if not already).
- ④ Extreme care shall be taken not to overfill the refrigeration system. Prior to recharging the system it shall be pressure tested with OFN. The system shall be leak tested on completion of charging but prior to commissioning. A follow up leak test shall be carried out prior to leaving the site.

Decommissioning

Before carrying out this procedure, it is essential that the technician is completely familiar with the equipment and all its detail. It is recommended good practice that all refrigerants are recovered safely. Prior to the task being carried out, an oil and refrigerant sample shall be taken in case analysis is required prior to re-use of reclaimed refrigerant. It is essential that electrical power is available before the task is commenced.

- ① Become familiar with the equipment and its operation.
- ② Isolate system electrically.
- ③ Before attempting the procedure ensure that:
 - Mechanical handling equipment is available, if required, for handling refrigerant cylinders;
 - All personal protective equipment is available and being used correctly;

- The recovery process is supervised at all times by a competent person;
 - Recovery equipment and cylinders conform to the appropriate standards.
- ① Pump down refrigerant system, if possible.
 - ② If a vacuum is not possible, make a manifold so that refrigerant can be removed from various parts of the system.
 - ③ Make sure that cylinder is situated on the scales before recovery takes place.
 - ④ Start the recovery machine and operate in accordance with manufacturer's instructions.
 - ⑤ Do not overfill cylinders. (No more than 80 % volume liquid charge).
 - ⑥ Do not exceed the maximum working pressure of the cylinder, even temporarily.
 - ⑦ When the cylinders have been filled correctly and the process completed, make sure that the cylinders and the equipment are removed from site promptly and all isolation valves on the equipment are closed off.
 - ⑧ Recovered refrigerant shall not be charged into another refrigeration system unless it has been cleaned and checked.

Labeling

Equipment shall be labeled stating that it has been decommissioned and emptied of refrigerant. The label shall be dated and signed. Ensure that there are labels on the equipment stating the equipment contains flammable refrigerant.

Recovery

When removing refrigerant from a system, either for servicing or decommissioning, it is recommended good practice that all refrigerants are removed safely. When transferring refrigerant into cylinders, ensure that only appropriate refrigerant recovery cylinders are employed. Ensure that the correct number of cylinders for holding the total system charge are available. All cylinders to be used are designated for the recovered refrigerant and labeled for that refrigerant (i.e. special cylinders for the recovery of refrigerant). Cylinders shall be complete with pressure relief valve and associated shut-off valves in good working order. Empty recovery cylinders are evacuated and, if possible, cooled before recovery occurs.

The recovery equipment shall be in good working order with a set of instructions concerning the equipment that is at hand and shall be suitable for the recovery of flammable refrigerants.

In addition, a set of calibrated weighing scales shall be available and in good working order.





Hoses shall be complete with leak-free disconnect couplings and in good condition. Before using the recovery machine, check that it is in satisfactory working order, has been properly maintained and that any associated electrical components are sealed to prevent ignition in the event of a refrigerant release. Consult manufacturer if in doubt.

The recovered refrigerant shall be returned to the refrigerant supplier in the correct recovery cylinder, and the relevant Waste Transfer Note arranged. Do not mix refrigerants in recovery units and especially not in cylinders.

If compressors or compressor oils are to be removed, ensure that they have been evacuated to an acceptable level to make certain that flammable refrigerant does not remain within the lubricant. The evacuation process shall be carried out prior to returning the compressor to the suppliers. Only electric heating to the compressor body shall be employed to accelerate this process. When oil is drained from a system, it shall be carried out safely.

1.2. The Symbol Description of the Device

The precautions listed here are divided into the following types. They are quite important, so be sure to follow them carefully. Meanings of DANGER, WARNING, CAUTION and NOTE symbols.

Symbols	Meaning	Description
	WARNING	The symbol shows that this appliance uses a flammable refrigerant. If the refrigerant is leaked and exposed to an external ignition source, there is a risk of fire.
	WARNING	The symbol shows that this appliance uses a low burning velocity material. Please keep away from fire source.
	CAUTION	This symbol shows that the operation manual should be read carefully.
	CAUTION	This symbol shows that a service personnel should be handling this equipment with reference to the installation manual.
	CAUTION	This symbol shows that information is available such as the operating manual or installation manual.

1.3. Statement

To keep users under safe working condition and property safety, please follow the instructions below:

- ① Wrong operation may result in injury or damage;
- ② Please install the unit in compliance with local laws, regulations and standards;
- ③ Confirm power voltage and frequency;
- ④ The unit is only used with grounding sockets;
- ⑤ Independent switch must be offered with the unit.

1.4. Safety Factors

The following safety factors need to be considered:

- ① Please read the following warnings before installation;
- ② Be sure to check the details that need attention, including safety factors;
- ③ After reading the installation instructions, be sure to save them for future reference.

 **Warning**

Make sure that the unit is installed safely and reliably.

- If the unit is not secure or not installed, it may cause damage. The minimum support weight required for installation is 21g/mm²

- If the unit was installed in a closed area or limited space, please consider the size of room and ventilation to prevent suffocation caused by refrigerant leakage.

① Use a specific wire and fasten it to terminal block so that the connection will prevent pressure from being applied to parts.

② Wrong wiring will cause fire.

Please connect power wire accurately according to wiring diagram on the manual to avoid burnout of the unit or fire.

③ Be sure to use correct material during installing.

Wrong parts or wrong materials may result in fire, electric shock, or falling of the unit.

④ Install on the ground safely, please read installation instructions.

Improper installation may result in fire, electric shock, falling of the unit, or water leaking.

⑤ Use professional tools for doing electrical work.

If power supply capacity is insufficient or circuit is not completed, it may cause fire or electric shock.

⑥ The unit must have grounding device.

If power supply does not have grounding device, be sure not to connect the unit.

⑦ The unit should be only removed and repaired by professional technician.

Improper movement or maintenance of the unit may cause water leakage, electric shock, or fire.

Please find a professional technician to do.

① Don't unplug or plug power during operation. It may cause fire or electric shock.

② Don't touch or operate the unit when your hands are wet. It may cause fire or electric shock.

③ Don't place heaters or other electrical appliances near the power wire. It may cause fire or electric shock.

④ The water must not be poured directly from the unit. Do not let water to permeate into the electrical components.

 **Warning**

① Do not install the unit in a location where there may be flammable gas.

② If there is flammable gas around the unit, it will cause explosion.

According to the instruction to carry out drainage system and pipeline work. If drainage system or pipeline is defective, water leakage will occur. And it should be disposed immediately to prevent other household products from getting wet and damage.

③ Do not clean the unit while power is on. Turn off power before cleaning the unit. If not it may result in injury from a high-speed fan or electric shock.

④ Stop operating the unit once there is a problem or an fault code.

Please turn off power and stop running the unit. Otherwise it may cause electric shock or fire.

⑤ Be careful when the unit is not packed or not installed.

Pay attention to sharp edges and fins of heat exchanger.

⑥ After installation or repair, please confirm refrigerant is not leaking.

If refrigerant is not enough, the unit will not work properly.

⑦ The installation of external unit must be flat and firm.

Avoid abnormal vibration and noise.

⑧ Don't put your fingers into fan and evaporator.

High speed running fan will result in serious injury.

⑨ This device is not designed for people who is physically or mentally weak (including children) and who does not have experience and knowledge of heating and cooling system. Unless it is used under direction and supervision of professional technician, or has received training on the using of this unit. Children must use it under supervision of an adult to ensure that they use the unit safely. If power wire is damaged, it must be replaced by a professional technician to avoid danger.

2. OVER VIEW OF THE UNIT

2.1. Accessories Supplied With the Unit

After unpacking, please check if you have all the following components.

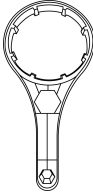
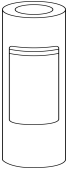
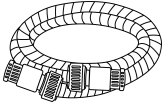
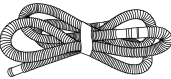
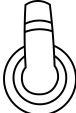
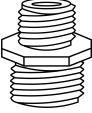
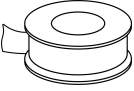
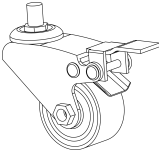
NO.	Components	Quantity	Appearance	NO.	Components	Quantity	Appearance
1	User Manual	1 pcs		7	Filter Wrench	1 pcs	
2	Filter Element	1 pcs		8	Inlet and Outlet Water Pipe	2 pcs	
3	Drain-pipe	1 pcs		10	Drain Nozzle	1 pcs	
4	Water Pipe Reducer	2 pcs		11	Teflon Tape	1 pcs	
5	Wheels	4 pcs					

2.2. Dimensions of the Unit

Dimensions (mm)

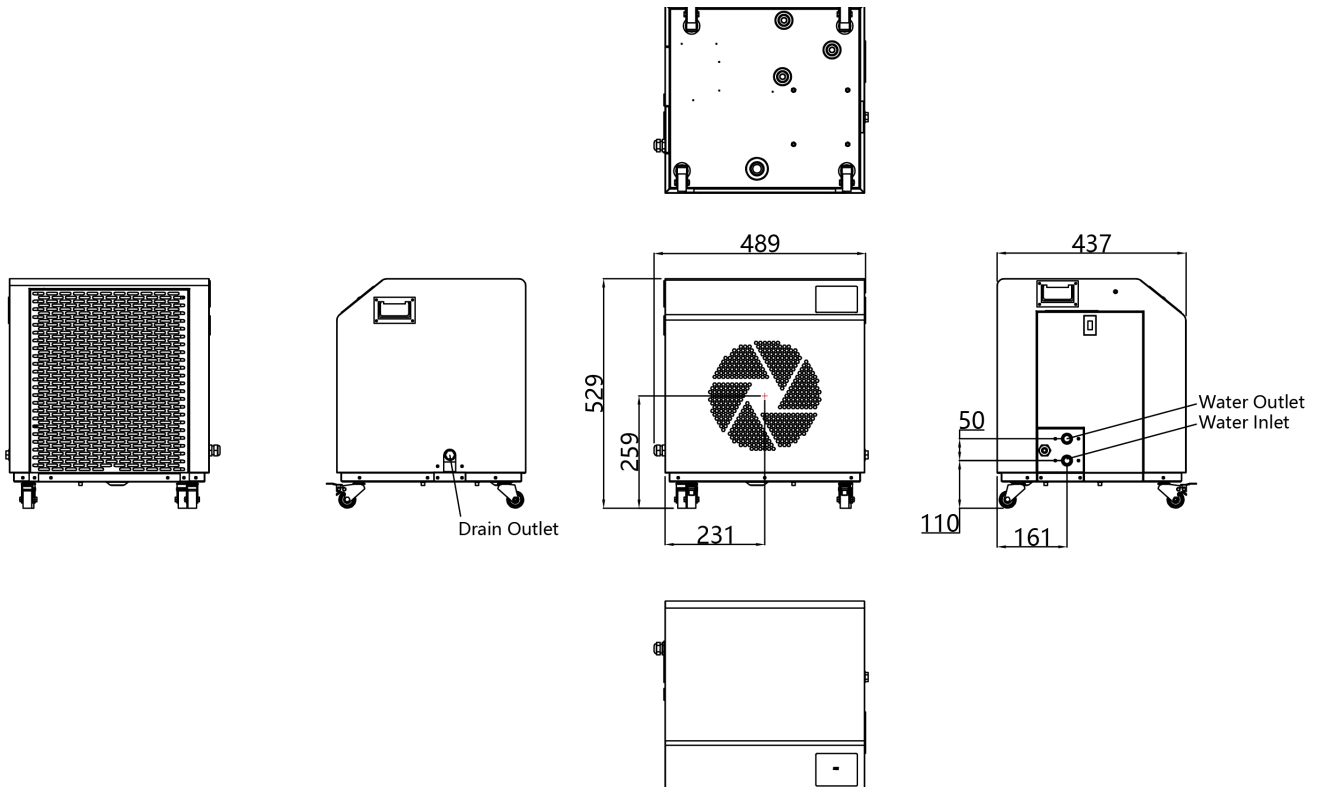

2.3. Main Parts of the Unit

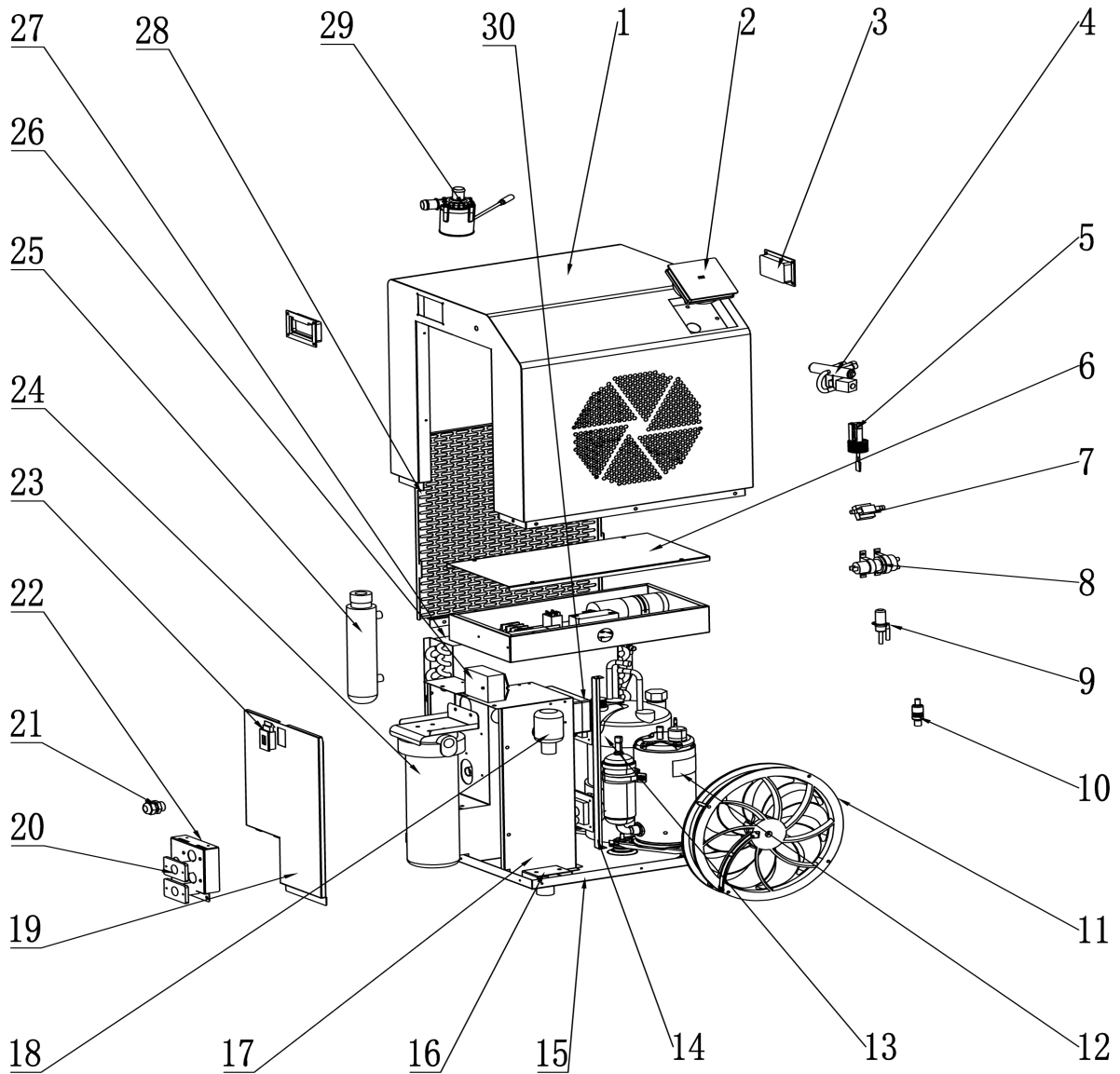

1	Shell Assembly	11	DC Fan Motor	21	PG13.5 Connector
2	Wire Controller	12	Compressor	22	Water Catch Plate
3	Iron Pull Hand	13	Titanium Heat Exchanger	23	Spring Snap
4	4-way Valve	14	Electrical Box Bracket	24	Filter
5	Water Flow Switch	15	Chassis Assembly	25	UV Light
6	Electrical Box Cover	16	Water Pump Support	26	UV Light Ballast
7	Water Flow Switch	17	Water Box Assembly	27	Evaporator Component
8	Self-priming Pump	18	Filter	28	Back Net
9	Electronic Expansion Valve	19	Nozzle Plate Assembly	29	Water Pump
10	Filter	20	PVC Joint	30	Ozone Disinfectant

Parts in the electric box

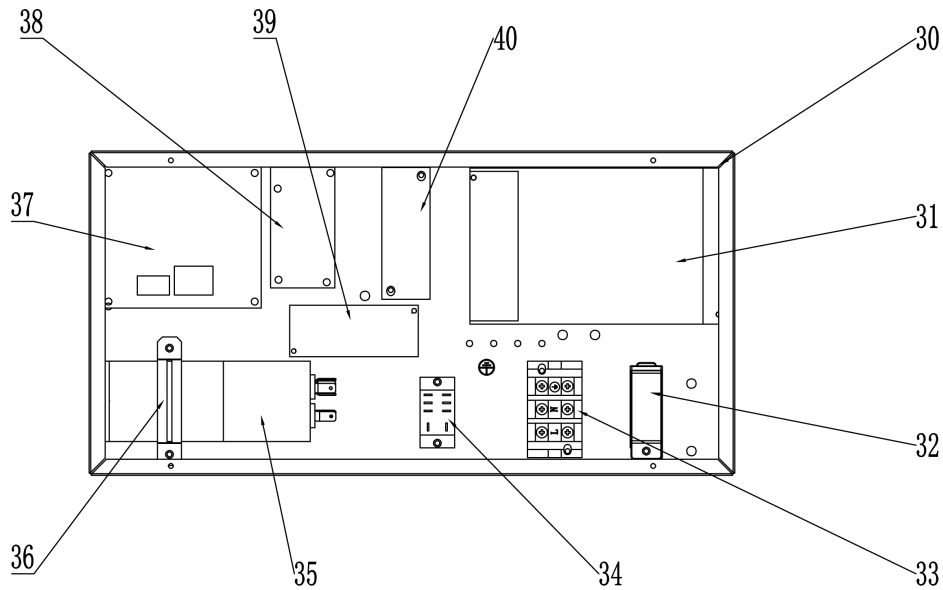

30	Electrical Box Assembly	34	Relay	38	Power Panel
31	Switching Power Supply	35	Capacity	39	Delay Output Relay Module
32	Terminal Board	36	Capacitance Clamp	40	Terminal Board
33	Terminal Board	37	Main Board		

2.4. Parameter of the Unit

Model	WSC-004
Type	Heating/Cooling
Water Volume&Chilling Time (From 23°C to 5°C)	50L: ≤0.65h 100L: ≤1.35h 200L: ≤2.7h 300L: ≤4.1h 500L: ≤6.75h
Heating Water Temp. Range (°C)	15~40
Cooling Water Temp. Range (°C)	2~28
Operating Ambient Temp. Range (°C)	-5~43
[Cooling] Ambient: 35°C, Water Outlet: 27°C	
Cooling Capacity (W)	2380
Power Input (W)	872
Current Value (A)	3.79
EER	2.73
[Cooling] Ambient: 27°C, Water Outlet: 10°C	

Cooling Capacity (W)	1820
Power Input (W)	672
Current Value (A)	2.92
EER	2.71
[Cooling] Ambient 15°C, Water Outlet: 5°C	
Cooling Capacity (W)	2030
Power Input (W)	601
Current Value (A)	2.61
EER	3.38
[Cooling] Ambient 15°C, Water Outlet: 2°C	
Cooling Capacity (W)	1625
Power Input (W)	482
Current Value (A)	2.1
EER	3.37
[Heating] Ambient: 27°C, Water Inlet: 26°C, Humidity: 80%	
Heating Capacity (W)	4210
Power Input (W)	663
Current Value (A)	2.88
COP	6.35
[Heating] Ambient: 15°C, Water Inlet: 26°C, Humidity: 70%	
Heating Capacity (W)	2550
Power Input (W)	646
Current Value (A)	2.81
COP	3.95
[Heating] Ambient: 27°C, Water Inlet: 38°C, Humidity: 80%	
Heating Capacity (W)	3400
Power Input (W)	947
Current Value (A)	4.12
COP	3.59
Pump Input Power (W)	65
Power Supply	220-240V~/50Hz
Max. Power Input (W)	1300
Max. Current (A)	5.65
Water Flow Volume (m³/h)	2.30
Refrigerant	R32
Max. Pressure(Mpa)	4.4
Sound Pressure Level at 1m [dB(A)]	
Sound Pressure Level at 10m [dB(A)]	
Water Pipe Connection (mm)	φ20
Water Heat Exchanger	Titanium
Circulation Pump	Built-in Water Pump With Self-priming System
Disinfection	Built-in Ozone Generator

Water Filter	Built-in
Transport wheels	Yes
Carry Handle	Yes
Easy Maintenance Plate	Yes
Quick Connectors	Yes
Water Proof Level	IPX4
Net Weight (kg)	33
Net Dimensions [(L×W×H) mm]	489×437×469

The above data are for reference only, the specific data are subject to actual product.

3. INSTALLATION AND CONNECTION

⚠ WARNING: The heat pump must be installed by a professional team. The users are not qualified to install by themselves, otherwise the heat pump might be damaged and risky for users' safety.

This section is provided for information purposes only and must be checked and adapted if necessary according to the actual installation conditions.

3.1. Transportation

1. When storing or moving the bath chiller, the bath chiller should be at the upright position.

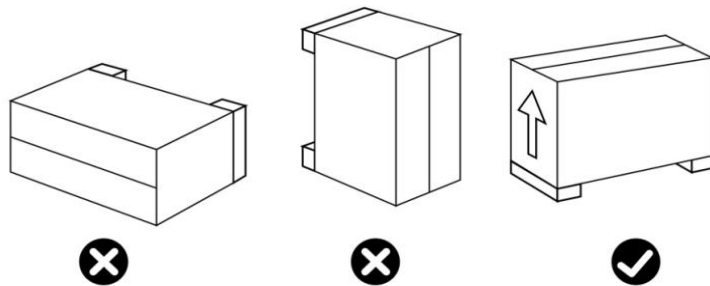

2. When moving the bath chiller, do not lift the water union since the titanium heat exchanger inside the bath chiller will be damaged.

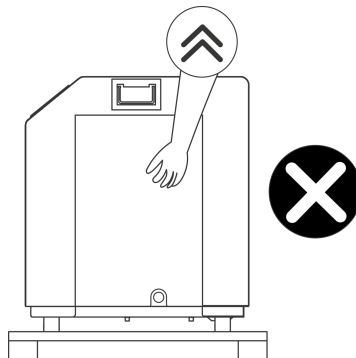

3.2. Installation Instruction

3.2.1 Pre-requirements

Equipment necessary for the installation of your bath chiller:

- ① Power supply cable suitable for the unit's power requirements.
- ② A set of wall plugs and expansion screws suitable to attach the unit to your support.
- ③ We recommend that you connect the unit to your installation by means of flexible PVC pipes in order to reduce the transmission of vibrations.
- ④ Suitable fastening studs may be used to raise the unit.

3.2.2 Location and Space

Please comply with the following rules concerning the choice of bath chiller location.

- ① The unit's future location must be easily accessible for convenient operation and maintenance.
- ② It must be installed on the ground, fixed ideally on a level concrete floor. Ensure that the floor is sufficiently stable and can support the weight of the unit.
- ③ A water drainage device must be provided close to the unit in order to protect the area where it is installed.
- ④ If necessary, the unit may be raised by using suitable mounting pads designed to support its weight.
- ⑤ Check that the unit is properly ventilated, that the air outlet is not facing the windows of neighbouring buildings and that the exhaust air cannot return. In addition, provide sufficient space around the unit for servicing and maintenance operations.
- ⑥ The unit must not be installed in an area exposed to oil, flammable gases, corrosive products, sulphur compounds or close to high frequency equipment.
- ⑦ To prevent mud splashes, do not install the unit near a road or track.
- ⑧ To avoid causing nuisance to neighbors, make sure the unit is installed so that it is positioned towards the area that is least sensitive to noise.
- ⑨ Keep the unit as much as possible out of the reach of children.
- ⑩ Installation space: (Unit: mm)

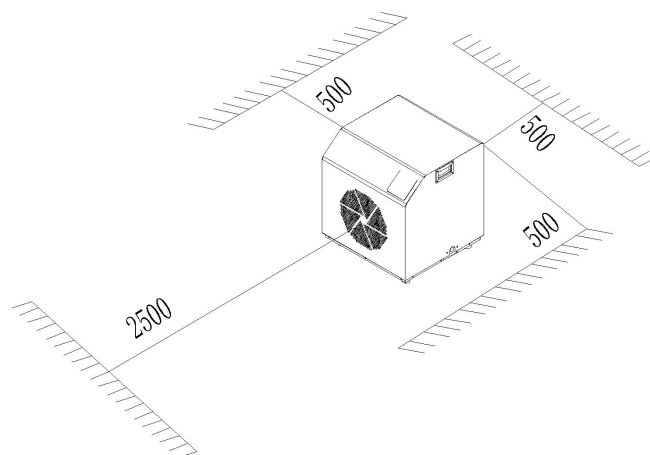

Do not put anything less than one meter in front of the bath chiller.
Leave 500 mm of empty space on the sides and back of the bath chiller and free ventilation above
Do not leave any obstacles above or in front of the device!

3.2.3 Installation Layout

Notice:

- The filter must be cleaned regularly to ensure that water in the system is clean and avoid blocking of filter..
- If the unit is not running during winter months, please disconnect power supply and let out drain water from unit through drainage valve. If ambient temp. of running unit is below 0°C, please keep water pump running.
- **Before entering the bucket, please turn off the ozone disinfection function**

The installation diagram is shown in the following figures:

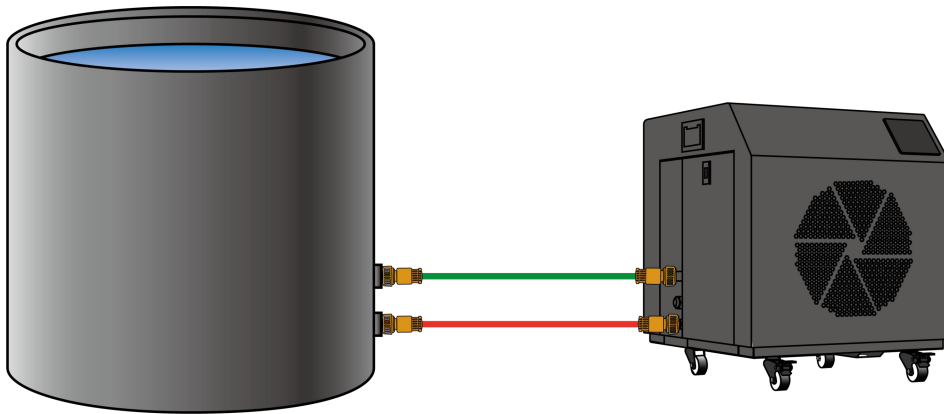

Figures1: there are water inlet and outlet in the bath bucket

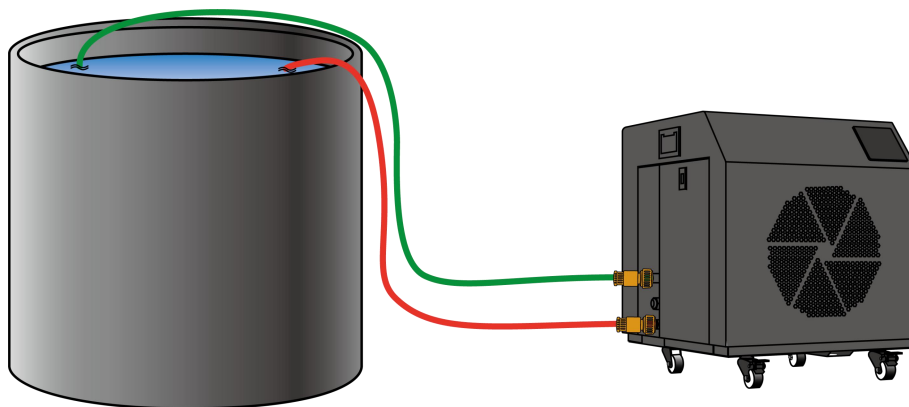

Figures2: there are no water inlet and outlet in the bath bucket

Note:

- The inlet and outlet water pipe should not be too close
- The water inlet pipe should be placed under water, but not too close to the bottom or wall of the bath bucket

3.2.4 Electrical Installation

To function safely and maintain the integrity of your electrical system, the unit must be connected to a general electricity supply in accordance with the following regulations:

- ① Upstream, the general electricity supply must be protected by a 30mA differential switch.
- ② The bath chiller must be connected to a suitable D-curve circuit breaker in accordance with current standards and regulations in the country where the system is installed.
- ③ The electricity supply cable must be adapted to match the unit's rated power and the length of wiring required by the installation. The cable must be suitable for outdoor use.
- ④ For a three-phase system, it is essential to connect the phases in the correct sequence. If the phases are inverted, the bath chiller's compressor will not work.
- ⑤ In places open to the public, it is mandatory to install an emergency stop button close to the bath chiller.

Model	Power Supply Wires		
	Electricity Supply	Cable Diameter	Specification
WSC-004	220-240V~/ 50Hz	3G 1.5mm ²	AWG 16

3.2.5 Electrical Connection

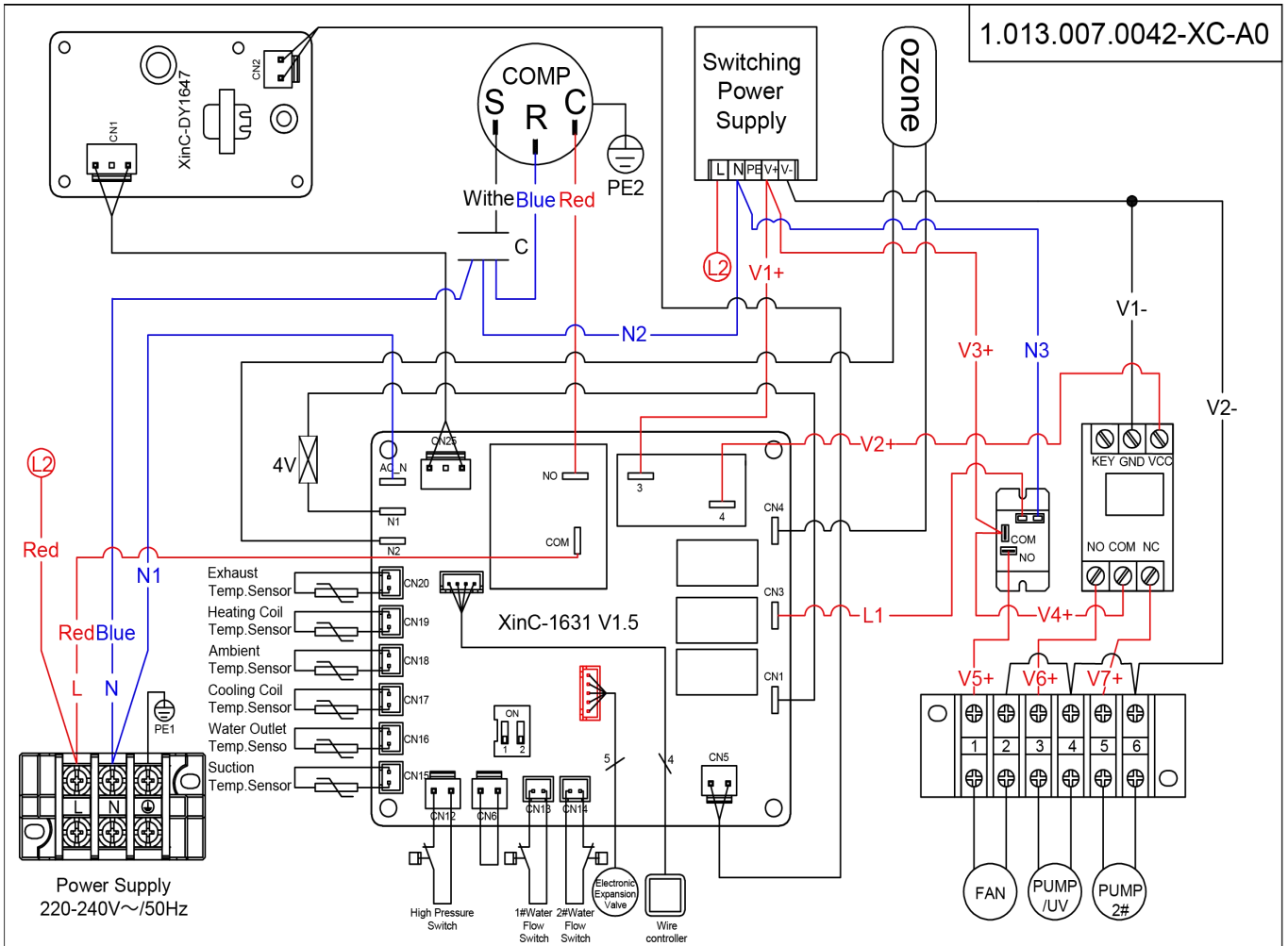

⚠ WARNING: Power supply of bath chiller must be disconnected before any operation.

Please comply with the following instruction to connect bath chiller.

Step 1: Prepare a socket

Step 2: Insert plug into socket as the following picture shows

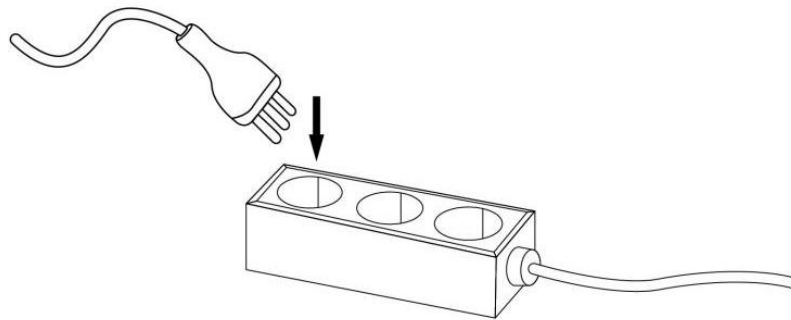

Plug Power Supply
220-240V~/50Hz

3.3. Trial After Installation

 **WARNING:** Please check all the wiring carefully before turning on the bath chiller.

3.3.1 Inspection Before Trial Running

Before running test, confirm below items and write √ in block;

<input type="checkbox"/>	Correct unit installation
<input type="checkbox"/>	Power supply voltage is the same as unit rated voltage
<input type="checkbox"/>	Correct piping and wiring
<input type="checkbox"/>	Air inlet & outlet port of unit is unblocked
<input type="checkbox"/>	Drainage and venting is unblocked and no water leaking
<input type="checkbox"/>	Leakage protector is working
<input type="checkbox"/>	Piping insulation is working
<input type="checkbox"/>	Ground wire is connected correctly

3.3.2 Trial Running

Step 1: Running test can begin after completing all installation;

Step 2: All wiring and piping should be connected well and carefully checked, then fill water tank with water before power is switched on;











Step 3: Emptying all air within pipes and water tank, press "on-off" button on control panel to run the unit at setting temp.;







Step 4: Items need to be checked during running test:













- ① During the first running, unit current is normal or not;
- ② Each function button on control panel is normal or not;
- ③ Display screen is normal or not;
- ④ Are there any leakage in the whole heating circulation system;
- ⑤ Condensate drain is normal or not;
- ⑥ Are there any abnormal sound or vibration during running?















4. REMOTE CONTROLLER OPERATION GUIDANCE



























NO.	Item	Icon	NO.	Item	Icon
1	Function or mode key		9	Wi-Fi	
2	Timer key		10	Defrosting	
3	" + " key		11	Alarm	
4	" - "key		12	Lock	
5	ON/OFF key		13	Timer on/off	

6	Heating mode		14	Real-time clock	
7	Automatic mode		15	Disinfection	
8	Cooling mode		16	Fan motor	

NO.	Item	Operation Way
1	ON/OFF	Under the main interface, press  1S to turn on/off.
2	Lock/Unlock	<ul style="list-style-type: none"> If the unit has no input operation for 60 seconds, the wire controller display screen will enter the dormant state, and the screen will automatically lock, and the  icon of the screen is light. In the state of locking machine, after pressing the  for 3 seconds, the buzzer start "beep", remove the lock button and the  icon turns off.
3	Mode Switching Function	Press  to switch modes between heating, cooling and automatic.
4	Query and set up of the user parameters	<ul style="list-style-type: none"> Under the main interface, long press  for 3s to enter the query interface, query the user parameters by pressing  or . In the user parameter query interface, select a parameter, press  to set the current user parameters. The parameter will become a flashing state, press  or  to modify the current user parameter value, and then press  to confirm the change of parameter value, and return the parameter query status. (PS : Parameters do not flash in query state; parameters flash in setting



		<p>state)</p> <ul style="list-style-type: none"> In the user parameter query or user parameter setting interface, if there is non-operation for 30 seconds, the changed parameter value will be automatically saved, exit the user parameter query interface or user parameter setting interface. Press  also can exit to main interface
5	Disinfection Function	<p>Parameter 9(0 Manual /1 Automatic,default is 0)</p> <ul style="list-style-type: none"> When the value of parameter 9 is 0, press  for 3 seconds to start disinfection function,  icon will occur. Press  for 3 seconds again to stop disinfection function,  icon will disappear. When the value of parameter 9 is 1, if the unit is on, the disinfection function will be started 20 minutes for every 20 minutes.
6	Real-time Clock Setting	<ul style="list-style-type: none"> In the main interface, press  for 5 seconds to enter the real-time clock setting interface, the hours and minutes of the clock will flash together. In the real-time clock setting interface, press the , the hour part will flash, and the minute part will stop flashing. At this time, press  or  to set the hour of the real-time clock. After setting the hour part, press  again, the numbers in the minute part will flash and the hour part will stop flashing. At this time, press  or  to set the minutes of the real-time clock. After the minute part is set, press  again to confirm the real-time clock setting and return to the main interface. In the real-time clock setting interface, press  to confirm the current real-time clock setting value and return to the main interface. In the real-time clock setting interface, if there is no key operation for 30 seconds, the current real-time clock setting value will be confirmed and return to the main interface.

7	Timer setting	<ul style="list-style-type: none"> • Under the main interface, press the  to enter the setting interface of entering the timing group. • When entering the timing setting interface, the timing group 1 flashes, and the wire controller has 2 timing groups. • In period 1, press  to enter the hour setting interface of timing startup time of group 1, and flash the number of timing startup time. Then press  or  to set the startup hours of time 1 group. • When the hour part is set, then press the , the number of the minute part is flashing, and press the  or  to set the minutes of the group 1. • When setting the startup minutes of group 1 is done, press the , then enter the hour of timing group 1 shutdown setting, the setting method is the same as above. • When the timing shutdown time is set, press the  to confirm the setting timing switch time of the current group, then press the  or , you can enter the next set of timing switch time setting, the setting method is consistent with the timing group 1. • If the time group is valid, the serial number of the time group is displayed under the main interface. • In a set of timing settings, if the timing startup time and the timing shutdown time are the same, the timing startup / shutdown of the group is invalid. • When timing period 1 or 2 flashes, long press the  for 3s to confirm the current timing setting, and the  or  will occur in the display. • When the timing period 1 or 2 flashes, long press the  for 3s to close the current timing, the  or  will be no longer displayed. • In the timing interface, keep non-operation for 30 seconds, confirm
---	---------------	--

		<p>the current timing and return to the main interface.</p> <ul style="list-style-type: none"> In the timing interface, press the  to confirm the current timing and return to the main interface.
8	Temp.Setting Function	Under the main interface, Press  or  , the set temperature can be adjusted
9	Return to the Main Interface	Press  to return to the main interface.
10	Reset Operation	<ul style="list-style-type: none"> Under the main interface of shutdown state, long press  and  for 5 seconds to restore the value of unit user parameters and factory parameters to the default state of factory parameters. Under the main interface of the shutdown state, long press the  and  for 3 seconds to reset the master E party parameter.

4.1. Key Operating Instruction

4.2. Parameter List

4.2.1 Query control table of unit temperature status.(Long press  for 3s to enter, and then press  and  to turn up and down the page query.)

Code	Parameter	Remark
T1	Exhaust temperature	
T2	Return gas temperature	
T3	Outlet temperature	
T4	Refrigeration coil temperature	
T5	Outdoor coil temperature	
T6	Outdoor ambient temperature	
1F	Main route electronic expansion valve opening degree	
od	Outdoor operation mode	1:heating 2:Cooling

OF	Speed of outdoor fan motor	AC: 1:High speed 2:Medium speed 3:Low speed DC: The actual speed=display value*10
dF	Defrosting state	
STF	Four-way valve switch	
Pu	Water pump switch	
HE1	Failure code history	
HE2	Failure code history	
HE3	Failure code history	
HE4	Failure code history	
Pr	Main board Protocol Version	
Sr	Main board software version	

4.2.2 Control table of unit user parameters

Users can query. Long press  for 3s to directly enter, press  and  to turn up and down the page query

Code	Parameter name	Range	Default value
L0	Heat setting value	15°C~40°C	27°C
L1	Set value of heating start-up deviation	0°C~18°C	2°C
L2	Deviation temperature setting for heating constant temperature shutdown	0°C~18°C	0°C
L3	Cooling setting value	2°C~35°C	20°C
L4	Refrigeration startup deviation setting value	0°C~18°C	2°C
L5	Deviation temperature setting for cooling constant temperature shutdown	0°C~18°C	0°C
L6	The Automatic mode sets the temperature	2°C~42°C	27°C
	Water pump working mode	0:The water pump is not closed	0

		during constant temperature shutdown. 1: When shutting down at constant temperature, the water pump delays the compressor to turn off for 60 seconds. Every (L8) minutes open 5 minutes	
L8	The running interval of the water pump when shutting down at constant temperature	3~180min	30

4.3. Error Code

Check list of unit fault codes	
Code	Fault description
E01	Exhaust temperature failure
E05	Fault of coil temperature
E09	Return gas temperature failure
E19	Water inlet temperature failure
E18	Outflow temperature failure
E21	Communication failure with the indoor unit
E22	Environmental temperature failure
P01	Water flow switch failure
P02	High pressure protection
P06	Water flow protection for self-priming pump
P11	Over protection of exhaust temperature
P15	Over protection of temperature difference between in and out of water
P16	Over cooling protection
P17	Anti-freezing protection
P25	Ambient temperature protection
P26	Over protection of Heat out water temperature
P27	Over protection of the outer coil tube temperature

4.4. Trouble Shooting

NO.	Fault	Analysis	Solution
1	High pressure protection	<ol style="list-style-type: none"> 1. Loose wiring or poor connection of high pressure switch 2. There is something wrong with high pressure switch 3. Main board is broken 4. Poor condensing <ol style="list-style-type: none"> 4.1 Water temperature is too high (over range operation). 4.2 Low water flow <ol style="list-style-type: none"> 4.2.1 The valve in water system is not open. 4.2.2 Waterway blockage, may appear in the heat exchanger or valve part. 4.2.3 Improper water pump selection 4.2.4 The water pump is broken . 5. Refrigerant system blockage, may appear in the throttle part. 6. Refrigerant system is mixed with air, maybe the vacuum is not enough. 	<ol style="list-style-type: none"> 1. Reconnect the wire. 2. Replace the high pressure switch. 3. Replace the main board. 4.1 Operate within the allowable range. 4.2.1 Open the valve. 4.2.2 Clean the blocked part or replace it . 4.2.3 Change the pump according to the water flow and water head. 4.2.4 Replace the water pump. 5. Clean or replace the clogged part. 6. Vacuumize and refill the refrigerant.
2	Water flow protection	<ol style="list-style-type: none"> 1. The connection between water flow switch and main board is poor. 2. The water flow switch is installed wrong. 3. Water flow switch failure. 4. Main board failure. 5. Low water flow <ol style="list-style-type: none"> 5.1 The water system is blocked. 5.2 Water pump is not suitable 5.3 Water pipe is small 5.4 The water flow switch is stuck and cannot be reset. 5.5 6. No water flow <ol style="list-style-type: none"> 6.1 The valve is not open. 6.2 The water pump is not working. 6.3 Water pump failure. 	<ol style="list-style-type: none"> 1. Reconnect the water flow switch cable 2. Install the water flow switch in the correct way. 3. Need to replace the water flow switch 4. Need to replace the motherboard 5.1 Clean or replace the blocked part. 5.2 Change the pump according to the water flow and water head. 5.3 Need to change the water pipe. 5.4 Reset the water flow switch manually. 6.1 Open the valve. 6.2 Turn on the pump. 6.3 Need to replace the water pump.

3	Exhaust protection	<ol style="list-style-type: none"> 1.Temp.sensor fault. 2.Water flow switch fault 3.Leakage happen,and refrigerant is not enough . 4.Low water flow <ol style="list-style-type: none"> 4.1 The water system is blocked. 4.2 Water pump is not suitable 4.3 Water pipe is small 4.4 The water flow switch is stuck and cannot be reset. 5. No water flow <ol style="list-style-type: none"> 5.1 The valve is not open. 5.2 The water pump is not working. 5.3 Water pump is broken . 	<ol style="list-style-type: none"> 1.Need to replace the temp.sensor. 2.Need to replace the water flow switch. 3.Repair the leakage,and refill the refrigerant according to the nameplate. 4.1Clean or replace the blocked part. 4.2 Change the pump according to the water flow and water head. 4.3 Need to change the water pipe. 4.4 Reset the water flow switch manually. 5.1 Open the valve. 5.2 Turn on the pump. 5.3 Need to replace the water pump.
4	Over-current protection	<ol style="list-style-type: none"> 1.Poor condensing <ol style="list-style-type: none"> 1.1 Water temp. is too high (over range operation). 1.2 Low water flow <ol style="list-style-type: none"> 1.2.1 The valve in water system is not open. 1.2.2 Waterway blockage, may appear in the heat exchanger or valve part. 1.2.3 Improper water pump selection 1.2.4 The water pump is broken . 2.Refrigerant system is mixed with air, maybe the vacuum is not enough. 3.The water pipe is blockaged. 4.The valve opening steps not enough. 5.Excessive refrigerant. 6.The fan is blockaged. 	<ol style="list-style-type: none"> 1.1 Operate within the allowable range. 1.2.1 Open the valve. 1.2.2 Clean the blocked part or replace it . 1.2.3 Change the pump according to the water flow and water head. 1.2.4 Replace the water pump. 2. Vacuumize and refill the refrigerant according to the nameplate. 3. Clean or replace the water pipe. 4. Turn the valve up appropriately. 5. Bleed out the refrigerant and refill the refrigerant according to the nameplate. 6. Clean out the blockage from the fan or replace the fan.
5	Ambient/Inlet/Outlet/Exhaust/Suction/External coil/Internal coil/sensor fault	<ol style="list-style-type: none"> 1. The connection between the temp. sensor and the main board is poor. 2. Temp. sensor fault. 3.The sensor resistance on the main board fault. 	<ol style="list-style-type: none"> 1.Reconnect the temp.sensor cable. 2.Replace the temp.sensor. 3.Replace the main board.
6	Communication fault	<ol style="list-style-type: none"> 1.The connection between wire controller and main board is poor. 2.Wire controller fault. 3. Main board fault. 4. Communication wire and strong electricity wire put together, resulting in power interference communication 	<ol style="list-style-type: none"> 1. Reconnect the wire controller cable. 2. Replace the wire controller. 3. Replace the main board. 4. Communication wire is placed separately from the strong electricity wire.

7	Anti-freeze protection	<ol style="list-style-type: none"> 1. Low ambient temp. running. 2. Low water temp. 	<ol style="list-style-type: none"> 1. When the ambient temp. is $\geq 2^{\circ}\text{C}$, exit the anti-freeze state. 2. When the inlet water temp. $> 15^{\circ}\text{C}$, exit the anti-freeze state.
8	High temp. difference between inlet and outlet water protection	<ol style="list-style-type: none"> 1. Inlet and outlet water temp. sensor fault. 2. Low water flow <ol style="list-style-type: none"> 2.1 The valve in water system is not open. 2.2 Waterway blockage, may appear in the heat exchanger or valve part. 2.3 The filter element is dirty 2.4 The water pump is broken . 2.5 Pipe size is too small. 3. Heat exchanger is fouling. 	<ol style="list-style-type: none"> 1. Need to replace the temp. sensor. 2.1 Clean or replace the blocked part. 2.2 Change the pump according to the water flow and water head. 2.3 Need to change the filter element. 2.4 Reset the water flow switch manually. 2.5 Choose the suitable pipe size. 3. Clean the dirt of the heat exchanger surface.

4.5. Other Malfunctions and Solutions(No display on wire controller)

NO.	Phenomenon	Cause	Solution
1	Unit is not running	<ol style="list-style-type: none"> 1. Power outage 2. Power switch is not connected 3. Power switch fuse is burned-out 4. Timing is not up 	<ol style="list-style-type: none"> 1. Please wait for power supply recovery 2. Connect power 3. Replace fuse 4. Please wait or cancel timing setting
2	Unit is not running after starting up	<ol style="list-style-type: none"> 1. Compressor protection time interval is not up 2. Water temp. of the unit does not reach starting up water temp. value 	<ol style="list-style-type: none"> 1. Please wait patiently for the end of protection time 2. Normal phenomenon and wait for water temp. to reach
3	Unit is running normally, but can't get the demand water temp.	<ol style="list-style-type: none"> 1. Improper temp. setting 2. Filter element is dirty 3. Air inlet port or outlet port of outdoor machine or indoor machine is blocked 	<ol style="list-style-type: none"> 1. Set up proper temp. 2. Replace the filter element 3. Clear tuyere obstruction
4	Unit is running automatically	Reach timing to start up	Please shutdown manually or cancel timing if needn't start up

4.6. Wi-Fi Settings

4.6.1 Software Installation

- ① Method 1: Search "Smart life" in your APP store ,install "".Click "GET" to install.

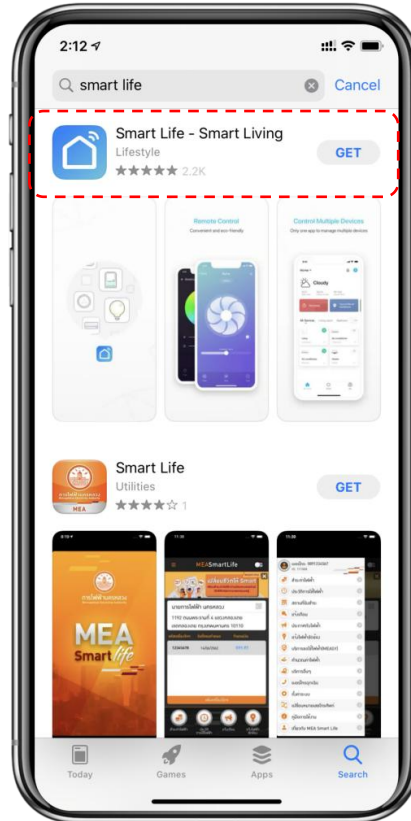

- ② Method 2: Scan the QR code below.



For IOS and Android Users

4.6.2 Software Startup

After installation,click "" on your desktop to start up Smart Life.

4.6.3 Software Registration and Configuration

1. Registration

- ① Users don't have account can click "Register" to create an account: Register → Enter your phone number → Get Verification Code → Enter Verification Code → Set Code;

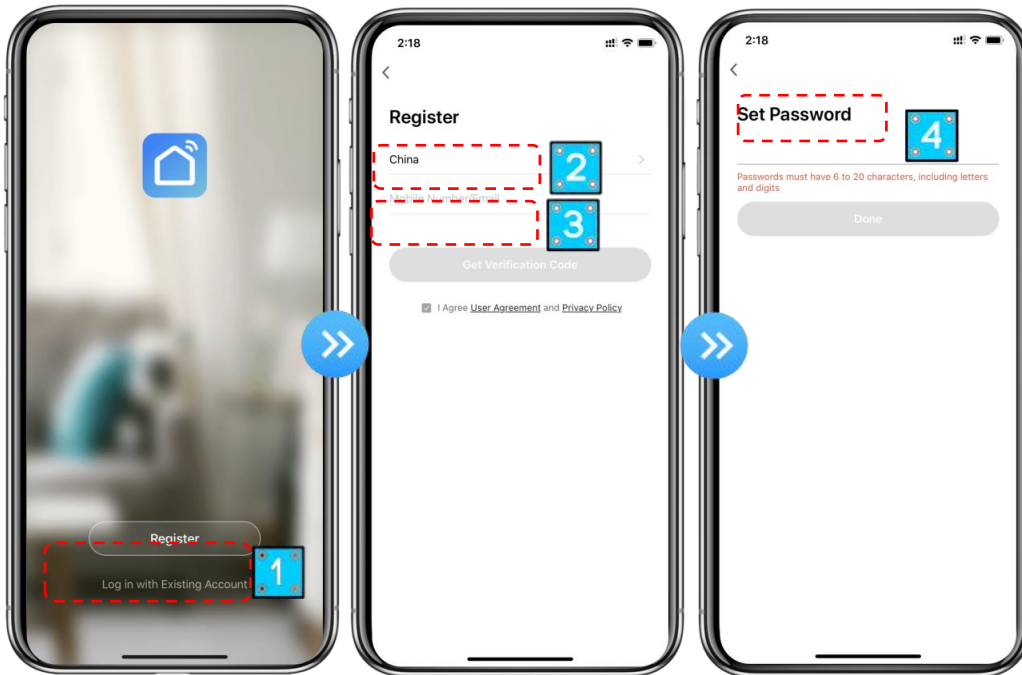

- ② After registration, you need to Create a Home: Create a Home → Set Home Name → Set Home Location → Add Rooms.

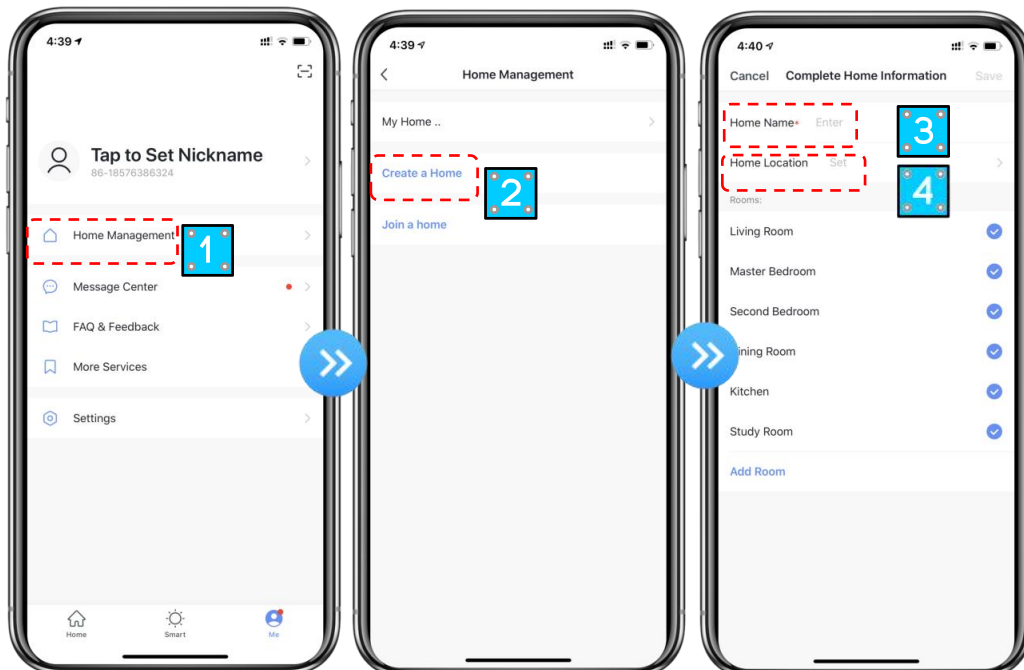

2. Account ID+ Password Login

- ① Existing accounts can be logged in directly, in the following order.

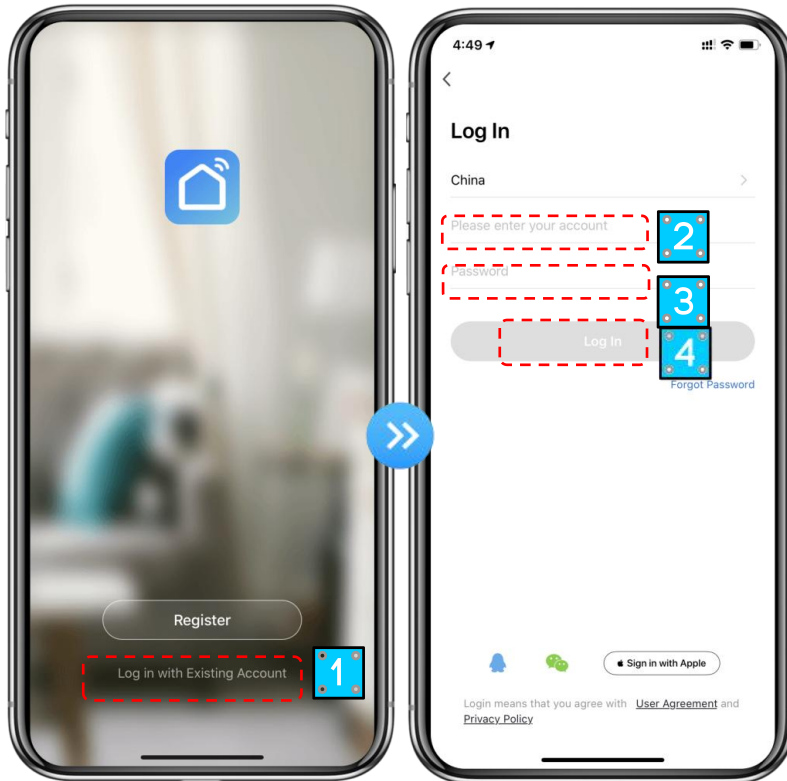

- ② If you forget your password you can choose to login with your verification code and select "Forgot Password": Enter your phone number → Get verification code .

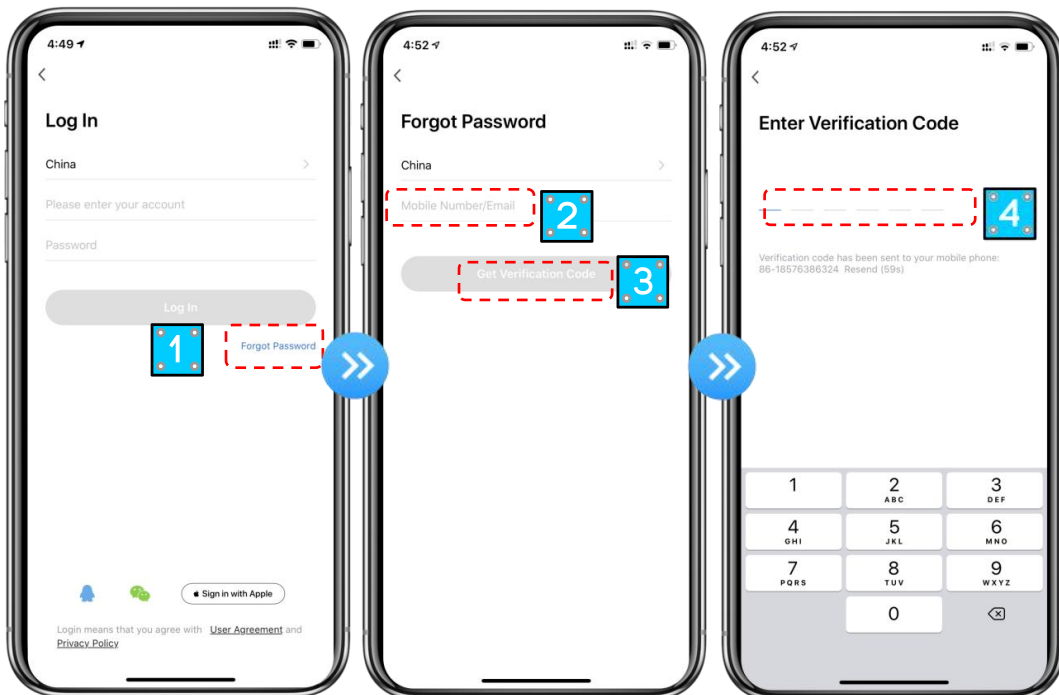

③ After creating a home or logged in, enter the main interface of APP.



Note:

Click the device to check the status, and you can set the operating mode, ON/OFF, timer. Click “+” to add devices.

2. Wi-Fi Module configuration steps:

Method 1

Step 1:

EZ Mode: When power is on, press and hold the "" and "" keys at the same time for 3 seconds to enter the distribution network. The "" icon will flash rapidly;.

Step 2:

Turn on the phone's Wi-Fi function and connect to the Wi-Fi hot-spot. The Wi-Fi hot-spot must be able to connect to the Internet normally;

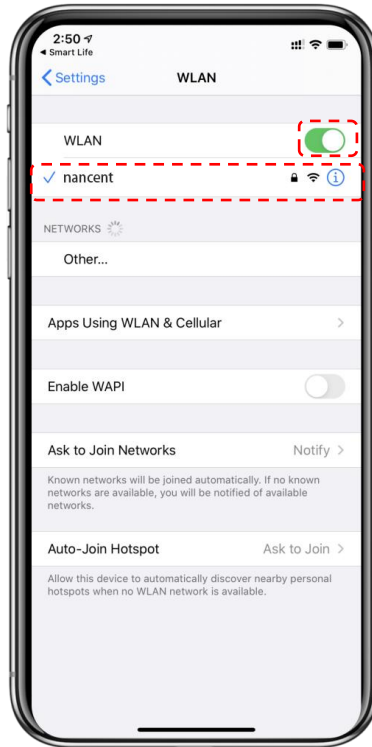

Step 3:

Open the "smart life" APP, log in into the main interface, click on the top right corner "+" or "add equipment" of the interface, enter the equipment type selection, the "Large Home Appliances", select "Smart Heat Pump" equipment and add equipment into the interface.

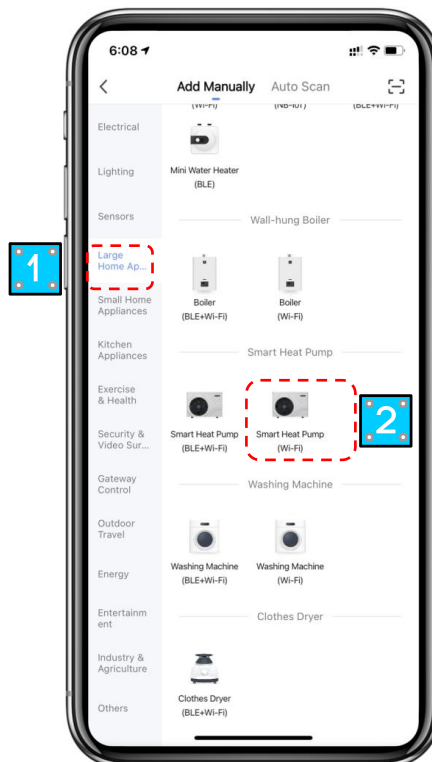

Step 4:

After selecting "Smart Heat Pump", enter the interface of "Add Equipment", and confirm that the wire controller has selected the EZ mode. After the indicator light under "📶" flashes rapidly, click "Confirm indicator rapidly blink".

Enter the Wi-Fi connection interface, enter the Wi-Fi password of the mobile phone (it must be the same as the Wi-Fi of the mobile phone), click "Next", and then directly enter the connected status of the device.

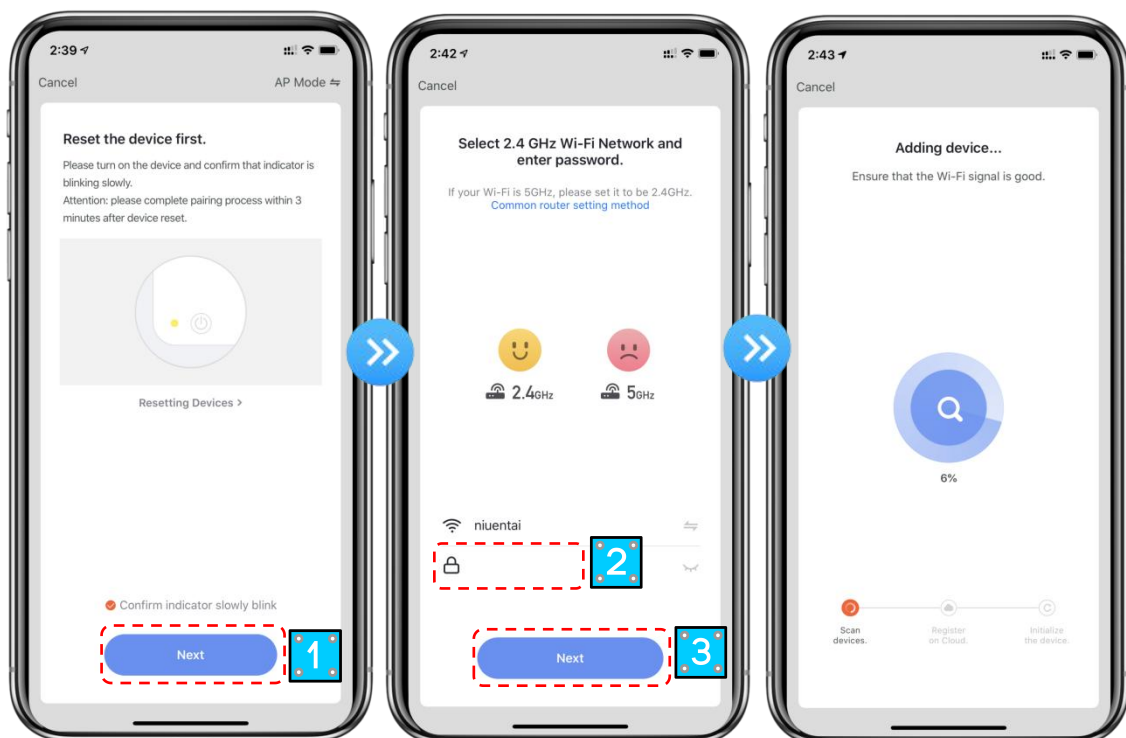

Step 5:

When "Scan devices", "Register on Cloud", "Initialize the device" are all completed, connect succeeds.

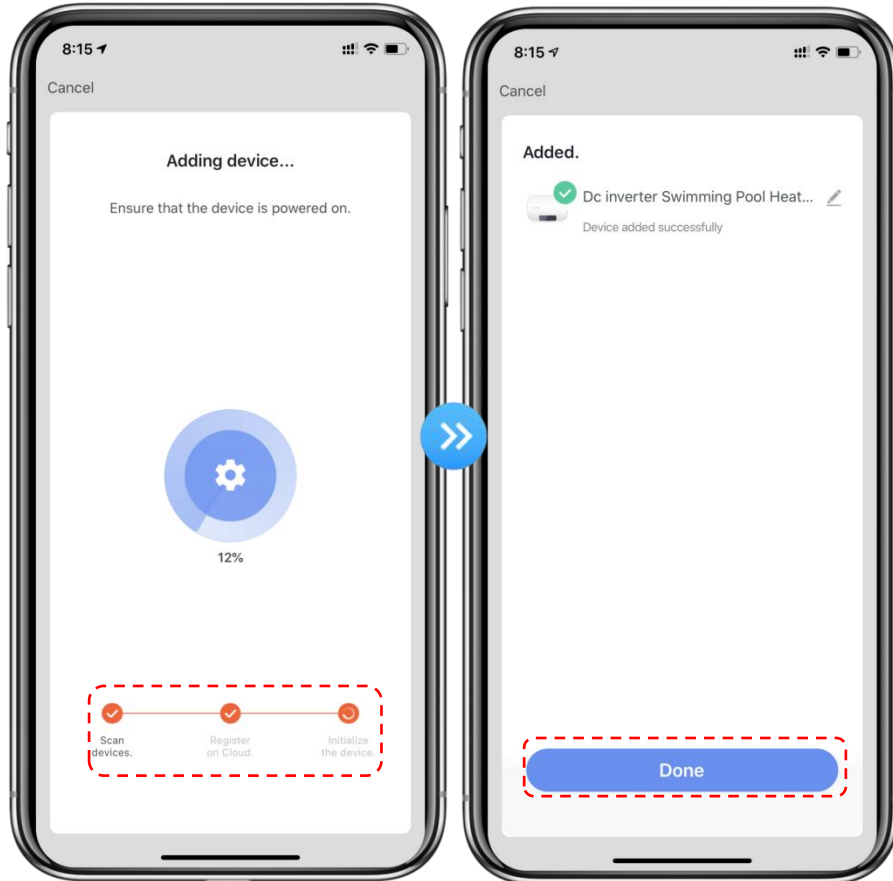

Method 2
Step 1

AP Mode: Press and hold the "  " and "  " and "  " keys at the same time for 3 seconds to enter the distribution network. The "  " icon will flash slowly.

Step 2&3

Same with EZ Mode above.

Step 4

After entering the add device interface, click "EZ Mode" in the upper right corner; Enter the AP mode to add the device interface, confirm that the AP mode has been selected, and click "Confirm indicator slowly blink".

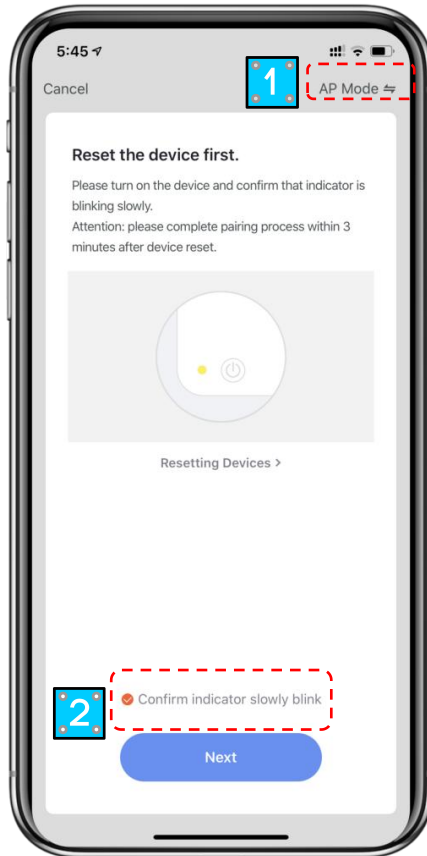

The interface of Wi-Fi connection will pop up, enter the Wi-Fi password of the mobile phone (it must be the same as the Wi-Fi of the mobile phone), click "Next", "Connect your mobile phone to the device's hot spot" will pop up, and click "Go to Connect";

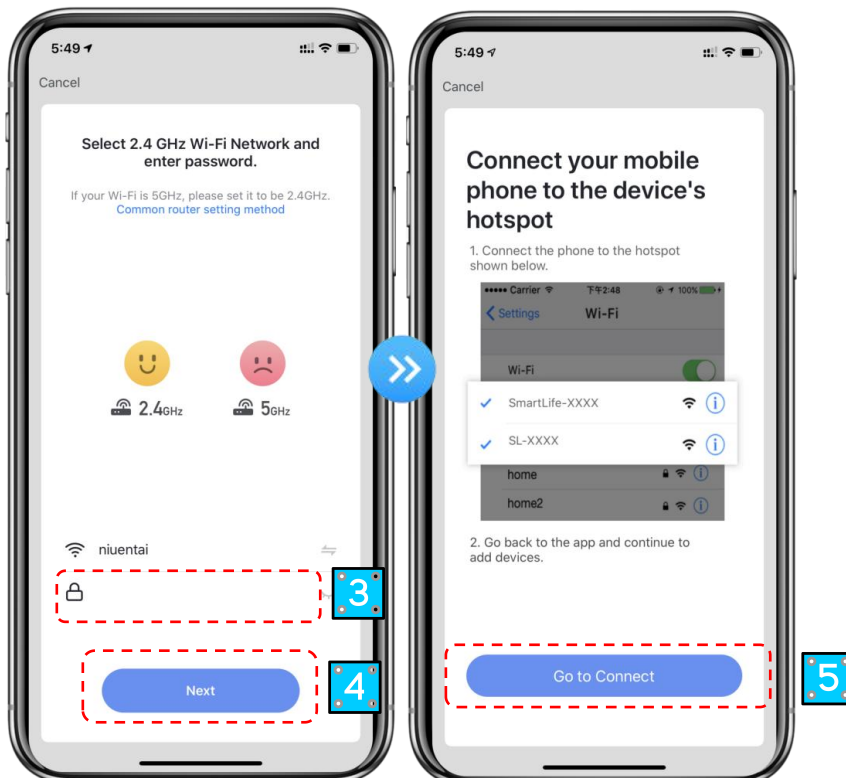

Enter the mobile phone Wi-Fi connection interface, find the “Smart Life_XXXX” connection, and the APP will automatically enter the device connection status.

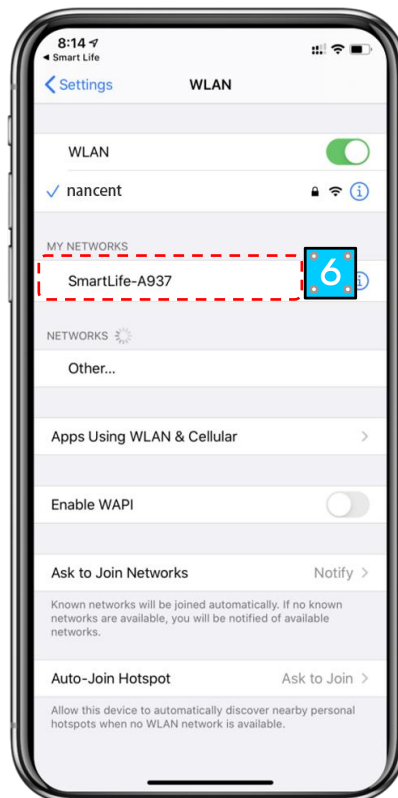

Step 5 : Same as EZ mode above.

Note: If the connection is failed, please enter the AP mode manually and reconnect according to the above steps.

4.6.4 Software Function Operation

- After the device is bound successfully, enter the operation interface of “Smart heat pump” (Device name, modifiable)
- In the main interface of “Smart Life”, click “Smart heat pump” to enter the operation interface.



① Back

② More: You can change device name, select device installation location, check networking status, add Shared users, create device cluster, view device information, and more.

③ Setting temp. adjustment: The circle slides counterclockwise to reduce the temp., but clockwise to increase the temp..

④ Target temp.

⑤ Current temp.

⑥ Mode switching: Click to select the mode to be switched.

⑦ ON/OFF

⑧ Timing: Click to add timing off/on time.

● **Modify device name**

Click in the following order to enter device details, and click "Device Name" to rename the device.

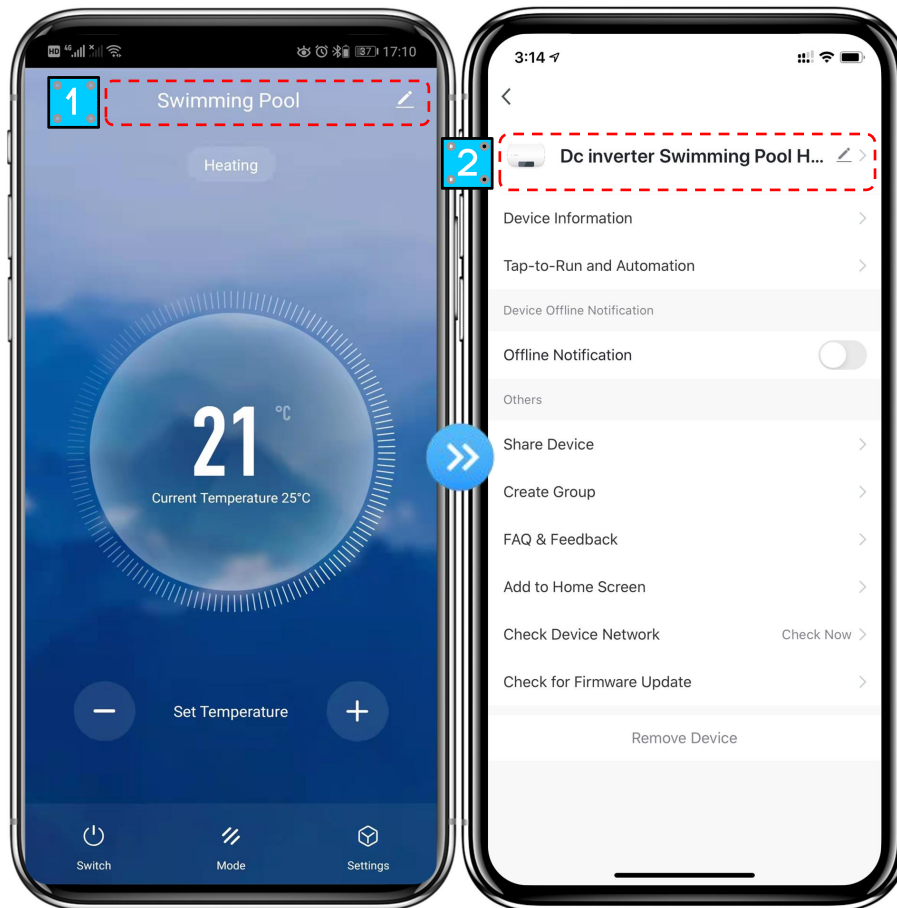

● Device sharing

- ◆ To share a bound device, the user should do so in the following order.
- ◆ After successful sharing, the list will be added to show the person shared
- ◆ If you want to delete the account you shared to, cross the selected account to the left, and delete it.
- ◆ The user interface is as follows.

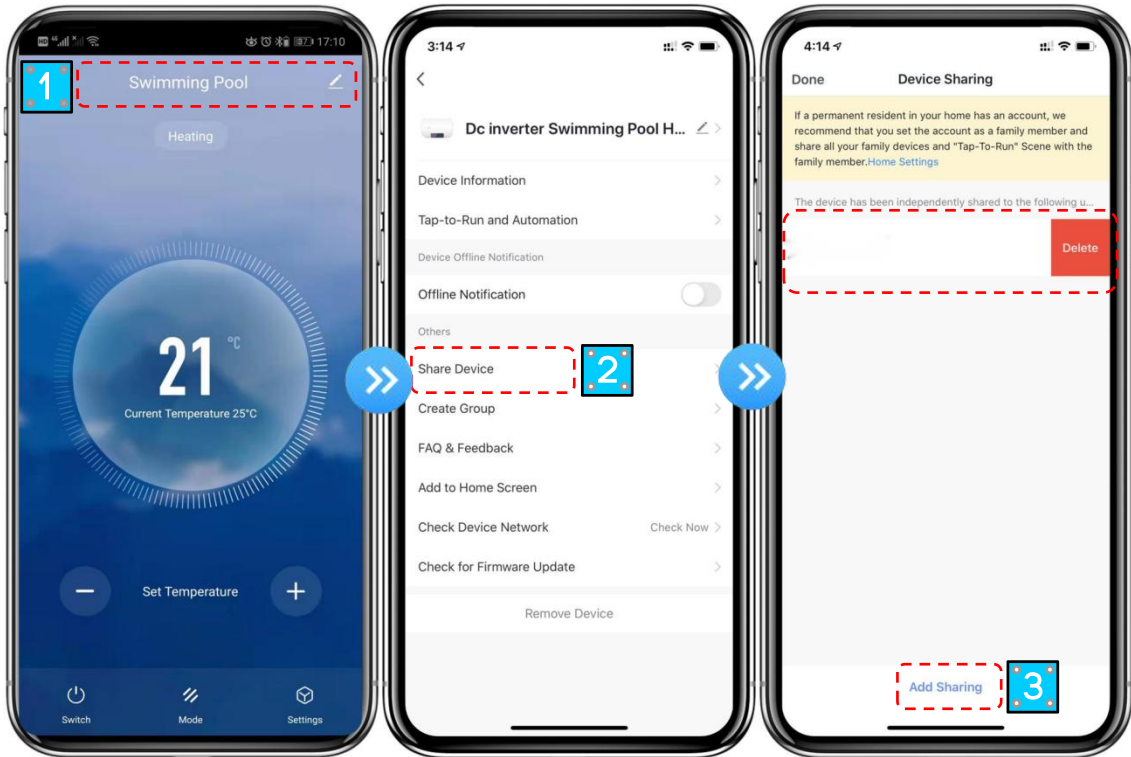

- ◆ Enter the account of the shared, click "Done", and the share success list shows the newly added account of the Shared.

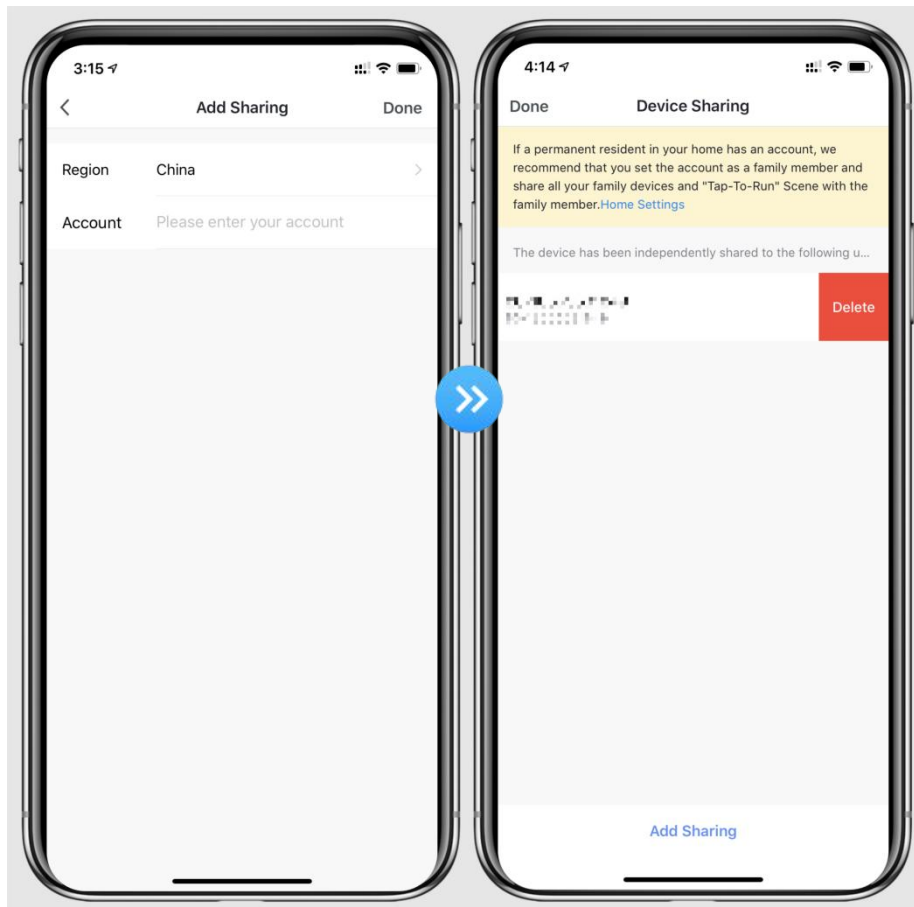

- ◆ The interface of the person to be shared is as follows. The received shared device is displayed.

Click it to operate and control the device.



● **Mode settings**

Click “” on the main interface to switch modes,select what you need.

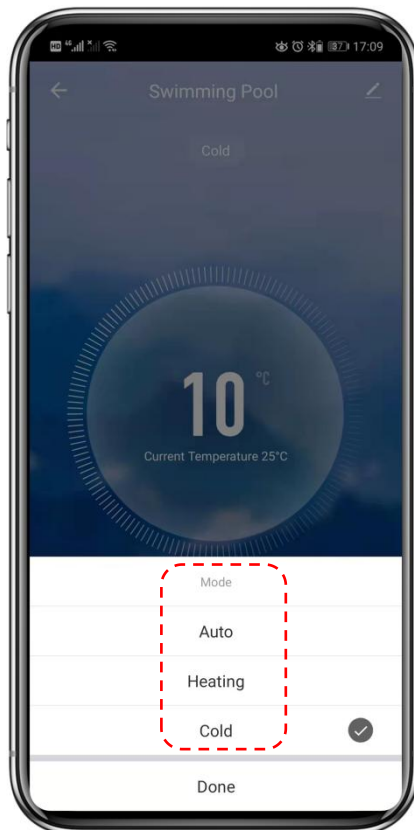

● Timer setting

1. Click “” on the main interface to enter timer setting interface, as shown below, click to add timer.

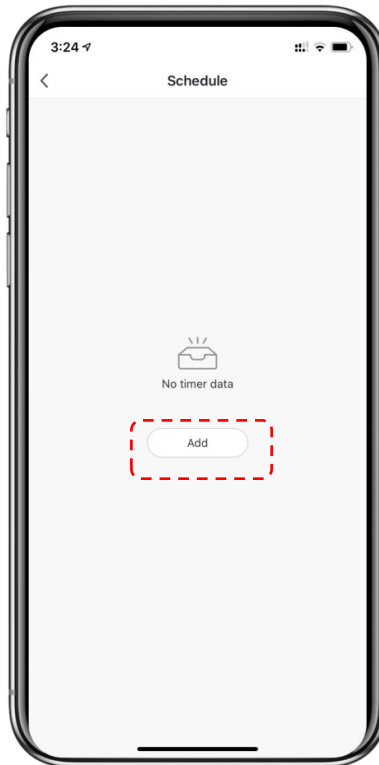

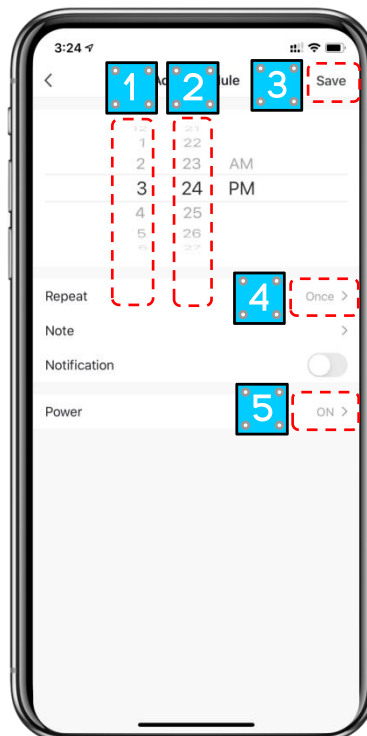

1. After entering timer setting, swipe up/down to set timer, set up repeat weeks and on/off, then click “save” to save your settings as follows.



- ① Hours
- ② Minutes
- ③ Set the repetition
- ④ Set power ON/OFF
- ⑤ Save your modification

4.3.5 Device Removal

Click “

The image displays two smartphone screens side-by-side. The left screen shows the main control interface for a 'Swimming Pool' device. At the top, there is a blue header with a back arrow, a blue square icon with a white number '1', and the text 'Swimming Pool' with an edit icon. Below the header, the word 'Heating' is visible. The main display features a large circular temperature gauge showing '21 °C' and 'Current Temperature 25°C'. At the bottom, there are three buttons: a power button labeled 'Switch', a 'Set Temperature' button with minus and plus icons, and a 'Mode' button. The right screen shows the 'Device Details' interface for 'Dc inverter Swimming Pool H...'. It has a back arrow at the top left and an edit icon at the top right. The list of options includes: 'Device Information', 'Tap-to-Run and Automation', 'Device Offline Notification', 'Offline Notification' (with a toggle switch), 'Others' (with a sub-header), 'Share Device', 'Create Group', 'FAQ & Feedback', 'Add to Home Screen', 'Check Device Network' (with a 'Check Now' button), 'Check for Firmware Update', and 'Remove Device' at the bottom.

5. MAINTENANCE AND WINTERZING

5.1 Maintenance

⚠ WARNING: Before undertaking maintenance work on the unit, ensure that you have disconnected the electrical power supply.

- **Cleaning**

- The bath chiller's casing must be cleaned with a damp cloth. The use of detergents or other household products could damage the surface of the casing and affect its properties.
- The evaporator at the rear of the bath chiller must be carefully cleaned with a vacuum cleaner and soft brush attachment.

- **Annual maintenance**

The following operations must be undertaken by a qualified person at least once a year.

- Carry out safety checks.
- Check the integrity of the electrical wiring.
- Check the earthing connections.
- Monitor the state of the pressure gauge and the presence of refrigerant.

5.2 Disassembly Guidelines

Tools:

- ① Phillips screwdriver
- ② Wrench
- ③ Flat-blade screwdriver

Step one: Take out the service plate (for filter and UV lamp replacement)

- ① Press the spring latch
- ② Pull out the service plate
- ③ Lift up to take out the service plate

As the following figure shows

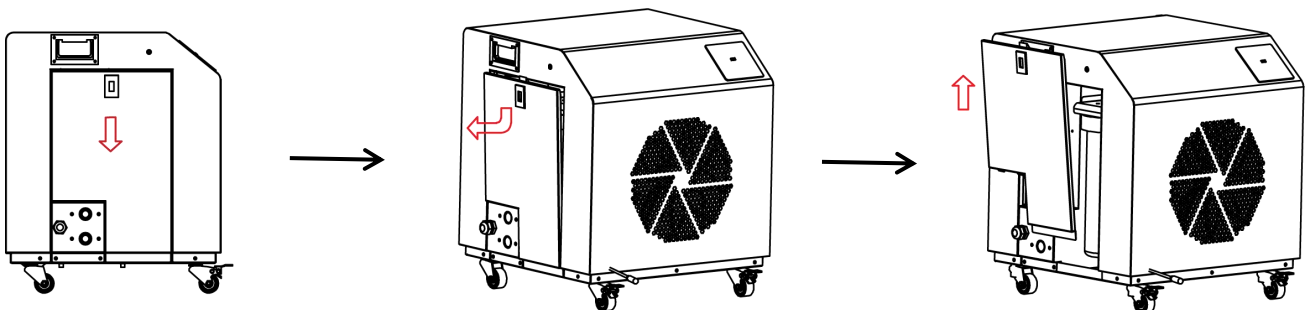

Step two: Take out the back net

- ① Take out the two screws
- ② Press and hold the back net, then slide down
- ③ Pull out the back net

As the following figure shows

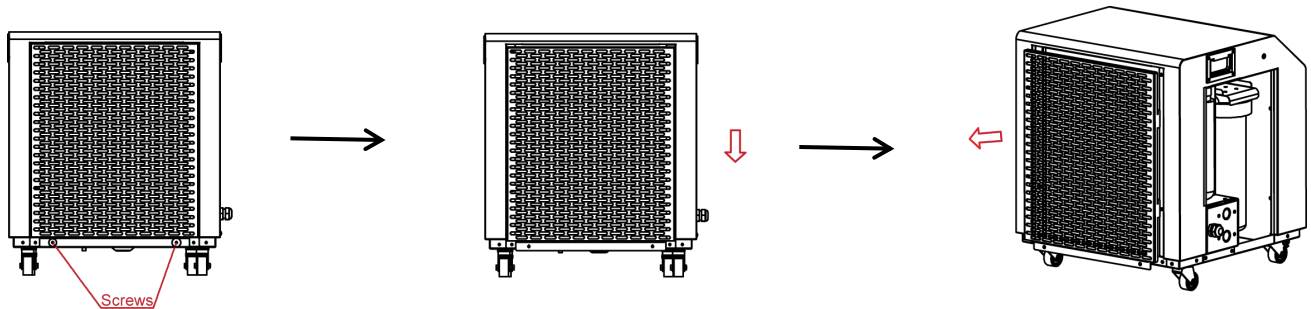

Step three: Take out the shell

- ① Remove the screws as shown
- ② Lift up the shell
- ③ Disconnect the cable between main board and wire controller
- ④ Take out the whole shell

As the following figure shows

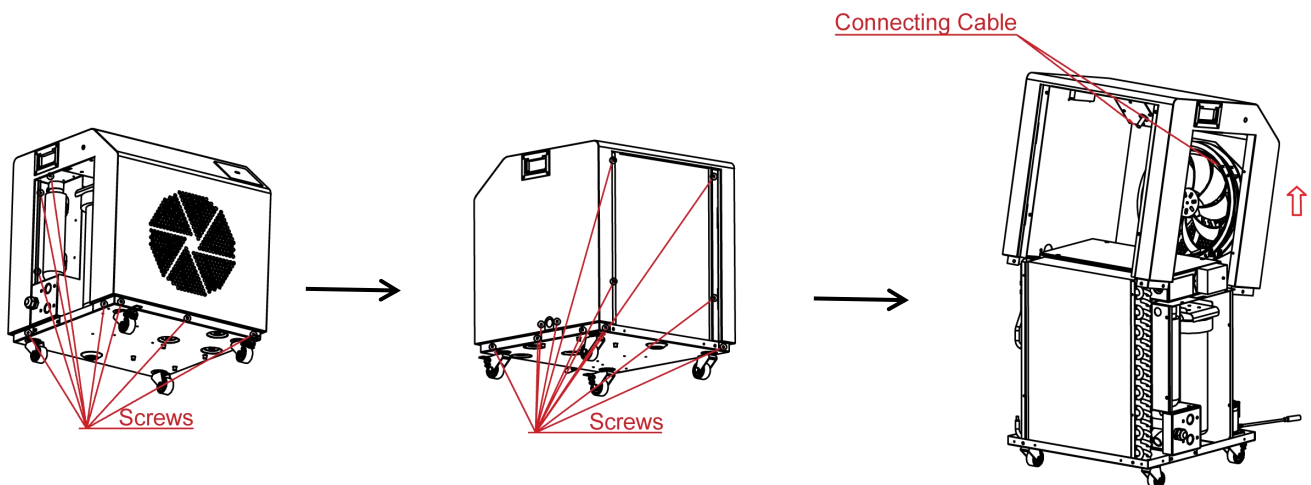

Step four: Take out the electric box cover

- ① Remove the four screws on the electrical box cover
- ② Lift it up and take out the electric box cover

As the following figure shows

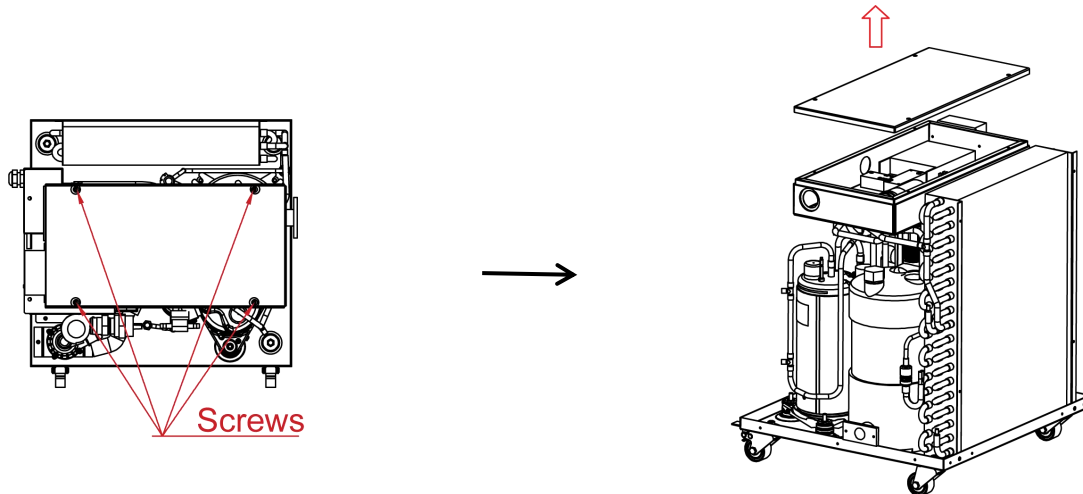

5.3 Filter Replacement

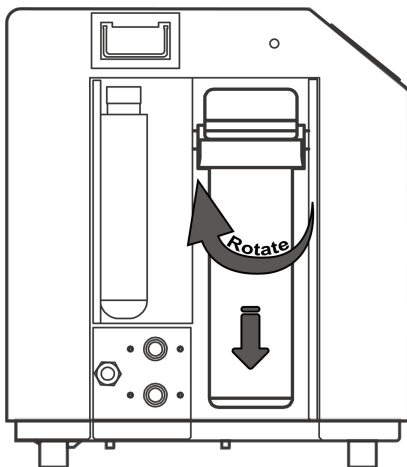

- If used frequently, it is recommended to replace the filter element every three months
- It is recommended to check the filter element every month. If the filter element is dirty, it needs to be replaced according to the following steps:

Use the included wrench to unscrew the filter bottle downwards and replace the filter element inside.

5.4 UV Lamp Replacement

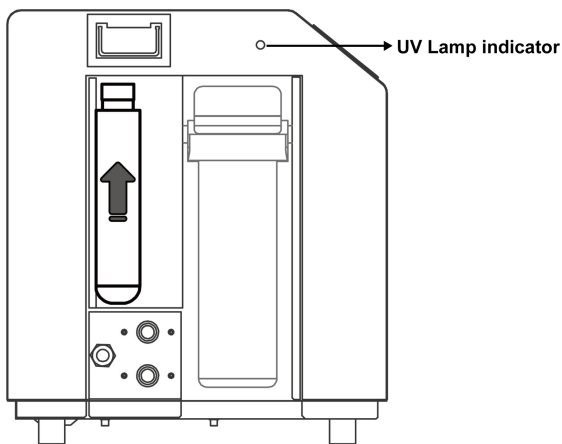

- If the UV lamp indicator turns red, please change the UV lamp as following steps:

Pull the upper part of the UV out of the slot, unscrew the top cover, and replace the light tube inside

5.5 Winterizing



**"CUT OFF" power supply of the heater
before cleaning, examination and repairing**

In winter season when you don't use the bath chiller:

- a. Cut off power supply to prevent any machine damage.
- b. Drain water clear of the machine.

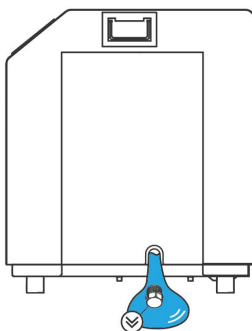

!! Important:

Unscrew the drain plug to let the water flow out. When the water in machine freezes in winter season, the titanium heat exchanger may be damaged.

- c. Cover the machine body when not in use.

