

Installation diagram

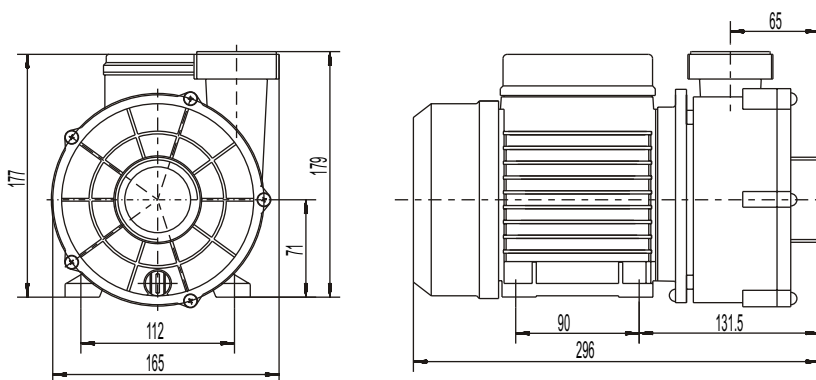

Model	Hz	Speed (rpm)	Power (P)		Qmax (L/min)	Hmax (m)	Curve
			kW	HP			
WTC50M	50	1400	0.25	0.35	240	3.8	Curve 1
	60	1700	0.25	0.35	240	3.8	Curve 1
	50	1400	0.18	0.25	180	2.8	Curve 2

V/Hz esp: See pump nameplate. liquid temperature: 4°C ~ 50°C
Storage temperature: -10°C ~ +50°C. Relative Air Humidity: 95% Max.

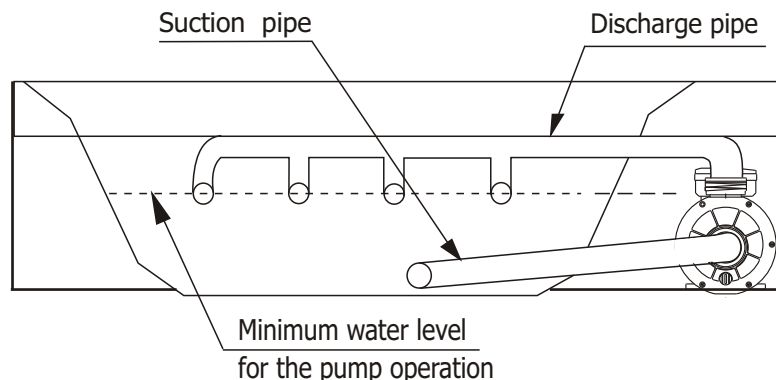

SPA CIRCULATION PUMP

INSTRUCTION MANUAL

WTC50M PUMP

IMPORTANT SAFETY INSTRUCTIONS

When installing and using this electrical equipment, basic safety precautions should always be followed, including the following:

- 1. READ AND FOLLOW ALL INSTRUCTIONS**
- 2. WARNING** To reduce the risk of injury, do not permit children to use this product unless they are closely supervised at all times.
- 3. WARNING** Risk of Electrical Shock. Connected only to grounding type receptacle protected by a ground fault circuit interrupter (GFCI). Contact a qualified electrician if you cannot verify that the receptacle is protected by GFCI.
- 4. CAUTION** Do not bury cord. Locate cord to minimize abuse from lawnmowers, hedge trimmers, and other equipment.
- 5. CAUTION** In case the running parts will injure people, don't make the electric pump running before then pipeline have been connected.
- 6. WARNING** To reduce the risk of electrical shock, replace damaged cord immediately.
- 7. WARNING** To reduce the risk of electrical shock, do not use extension cord to connect unit electric supply; provide a properly located outlet.
- 8. CAUTION** Jetpump for jetted bathtubs, spas, swimming pools, massage tubs, cleaning system.
- 9. Do not install within an outer enclosure or**
- 10.** This appliance is not intended for use by young children or infirm persons unless they have been adequately supervised by a responsible person to ensure that they can use the appliance safely.
- 11.** This appliance can be used by children aged from 8 years and above if they have been given supervision or instruction concerning use of the appliance in a safe way and understand the hazards involved. Cleaning and user maintenance shall not be made by children unless they are older than 8 and above and supervised. Keep the appliance and its cord out of reach of children aged less than 8 years.
- Appliance can be used by persons with reduced physical, sensory or mental capabilities or lack of experience and knowledge if they have been given supervision or instruction concerning use of the appliance in a safe way and understand the hazards involved.
- Children shall not play with the appliance.
- 12. FOR INDOOR USE ONLY.**
- 13. SAVE THESE INSTRUCTIONS**



Do not dispose of electrical appliances as unsorted municipal waste, use separate collection facilities. Contact your local government for information regarding the collection systems available. If electrical appliances are disposed of in landfills or dumps, hazardous substances can leak into the groundwater and get into the food chain, damaging your health and well-being.

1. General

These instructions are for correct installation, and optimum performance of the SPA pumps, so they should be read carefully. These are single-stage centrifugal pumps designed to operate with compact hydromassage equipment. They are equipped with a total-emptying system to prevent the discharge of residual liquid in each stopping.

These units are designed to operate with clean water at a maximum water temperature of 50°C. Built of top quality materials, they are subjected to strict hydraulic and electrical controls and are carefully verified. Correct installation is ensured by following these instructions and those of the wiring diagram; otherwise, over loads may be produced in the motor. We decline responsibility for any damage caused by not following these instructions.

General notes - ErP (ecological design-) directive

The benchmark for most efficient water pumps is $MEI \geq 0.70$

The efficiency of a pump with a trimmed impeller is usually lower than that of a pump with the full impeller diameter. The trimming of the impeller will adapt the pump to a fixed duty point, leading to reduced energy consumption.

The minimum efficiency index (MEI) is based on the full impeller diameter.

The operation of this water pump with variable duty points may be more efficient and economic when controlled, for example, by the use of a variable speed drive that matches the pump duty to the system.

Information on benchmark efficiency is available at www.lingxiao.com.cn/

2. Installation

⚠ The pumps should be installed horizontally, securing them with screws through the holes in the supports to prevent undesirable noise and vibration.

The suction pipe of the pump should be as short as possible.

The rating Label must be visible after installation. Parts containing live parts, except parts supplied with safety extra low voltage < 12V, must be inaccessible to a person in the bath. Class I appliances must be permanently connected to fixed wiring. Part including electrical components except remote control devices must be located or fixed so that they cannot enter the bath.

3. Pipe Assembly

The suction and discharge pipes should have a diameter equal to or greater than that of the intake tapping of the pump.

Avoid traps as, in addition to affecting efficiency, they impede total overall emptying.

The suction and discharge pipes should not rest on the pump in any case.

Seal all the connectors and unions well. Avoid any dripping on the motor, which would unfailingly damage it.

4. Electrical connection

The electrical installation should have a multiple separation system with contacts opening at least 3mm.

⚠ For continued protection against possible electric shock this unit is to be mounted to the base in accordance with the installation instructions.

The protection of the system should be based on a residual current device (RCD) with a rated tripping current not exceeding 30mA. The supply cable should comply with EMC standards (2). Single-phase motors have built-in thermal protection. The electric connection must be carried out by qualified staff following strictly the "EN60335-2-60" standard.

Be sure that the earth cable connection is correctly made.

Be sure that the equipotential connection between the bath and the pump is correctly made.

Wires serving as equipotential bonding conductors shall have a cross-sectional area between 2.5 and 6mm² and shall be equipped with the terminal suitable receptacle.

5. Controls Prior to Initial Start-up

⚠ Verify that the pump shaft turns freely.

Check that the mains voltage and frequency are according to the nameplate.

The hydromassage assembly should be equipped with a system to prevent the pump from starting up if a minimum water level is not present.

Check the rotating direction of the motor, which should concur with that indicated on the fan cover.

If the motor does not start up, try to locate the problem in the table of most common faults and their possible solutions that is provided further on.

THE PUMP SHOULD NEVER OPERATE DRY.

6. Start-up

Start electrically the pump only when the suction and discharge pipes are connected to the corresponding inlets and outlets. Check that there is no obstacle in the pipes.

Apply voltage to the motor and suitably adjust the jets to obtain the desired flow.

7. Maintenance and clean

⚠ Our pumps for hydromassage facilities do not require any special maintenance or programming.

If the pump will be idle for a long period of time, it is recommended to disassemble, clean and store it in a dry, well-ventilated place. If the supply cord is damaged, it must be replaced by the manufacturer or its service agent or a similarly qualified person to a hazard.

Pump can be automatically empty water after correct installation.

When the pump needs to clean (1) filling with water up to level position of bathtub's nozzle, (2) operating 2-3 minutes, (3) exhausting water of SPA engine stop.

8. Trouble Shooting Guide

SYMPTOM	POSSIBLE CAUSE	CHECK
PUMP DOES NOT TURN	NO POWER TO PUMP	-incoming power to the pump? -Is circuit breaker on? -Is GFCI operating properly? -Is the air switch plugged in?
PUMP NOT PUMPING PROPERLY	BLOCKAGE OR LEAK	-Jets should be pointed away from the suction inlet so air is not forced into pump suction -Is the in-tub suction inlet blocked or covered? -Is there any debris in the pump housing? -Is there a leak in the piping or the pump?
	LOW VOLTAGE	-Is the proper voltage applied to the pump? -Is there an extension cord being used?

Performance curves

