

INSTALLATION AND OPERATING INSTRUCTIONS

1. Dimensions and specifications

1.1. SURFACE WINDER

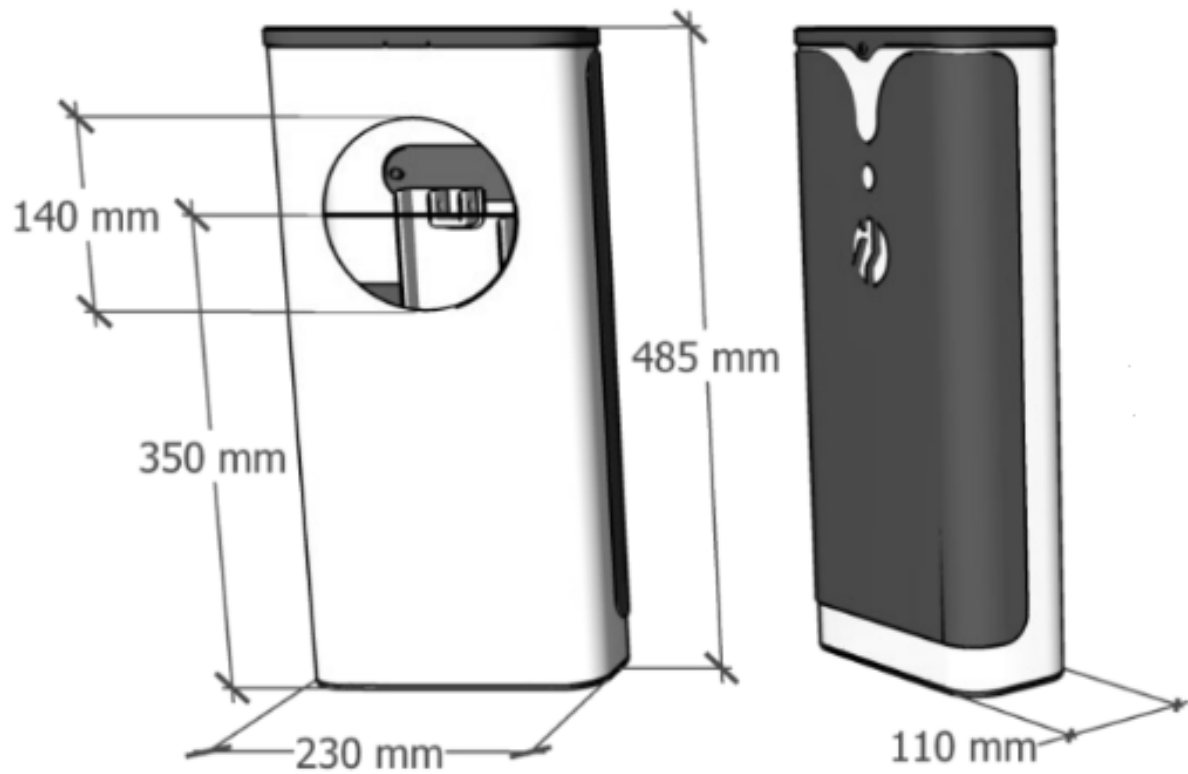

1.2 ALUMINIUM SHAFT

24V 120 Nm TUBULAR MOTOR WITH BUILT-IN LIMIT SWITCHES

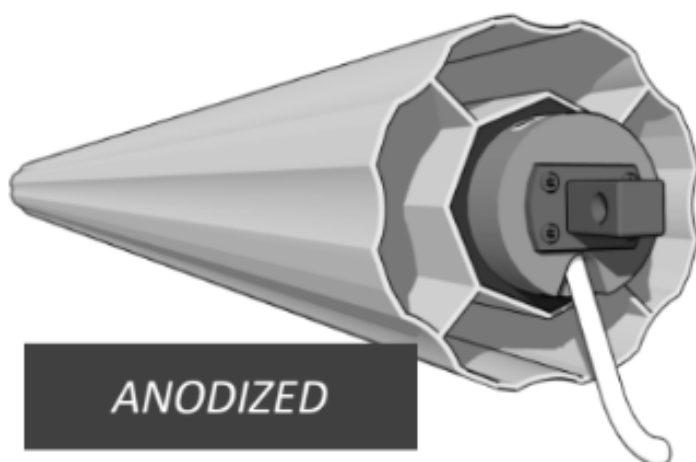

POOL LENGTH (m)	REWINDER DIAMETER (mm)	NUMBER OF SLATS (PCS)
1	200	16
2	250	33
3	300	50
4	340	66
5	370	82
6	390	98
7	420	114
8	440	131
9	450	148
10	470	164
11	480	180
12	500	197
13	520	213
14	530	229
15	540	245
16	560	261
17	580	278
18	590	294

1.3 POST BASE

